

SWIVEL ARMS

Round Tooling | Features and Benefits

AC-SA Series Accessory Mount Swivel Arms



Features:

- Fixed adjustment every 90 degrees
- Mounts to a 1 inch or 25mm tube
- Clamps to a Ø28.6mm [1.125"] (B112) Spherical Ball

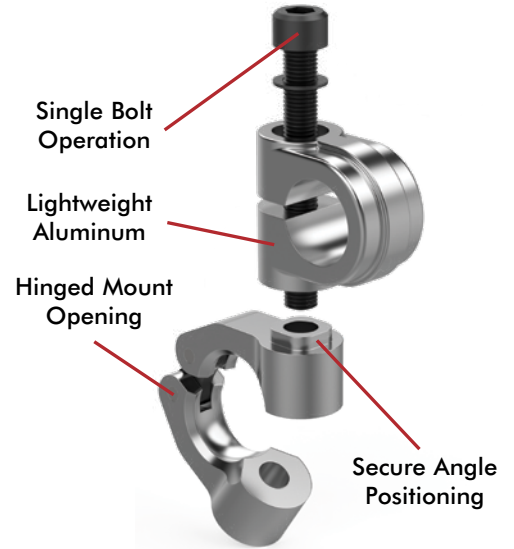

AC-SA10-100-B112-02
AC-SA25-25M-B112-50

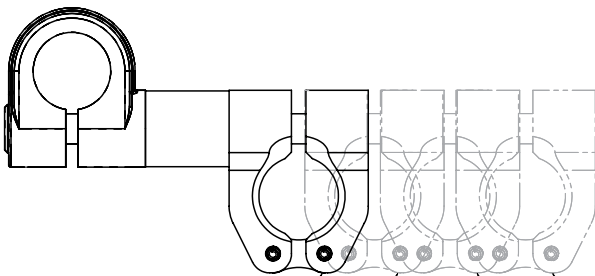

AC-SA10-100-B112-03
AC-SA25-25M-B112-75

AC-SA10-100-B112-06
AC-SA25-25M-B112-150

AC-SA10-100-B112-04
AC-SA25-25M-B112-100

AC-SA10-100-B112-05
AC-SA25-25M-B112-125

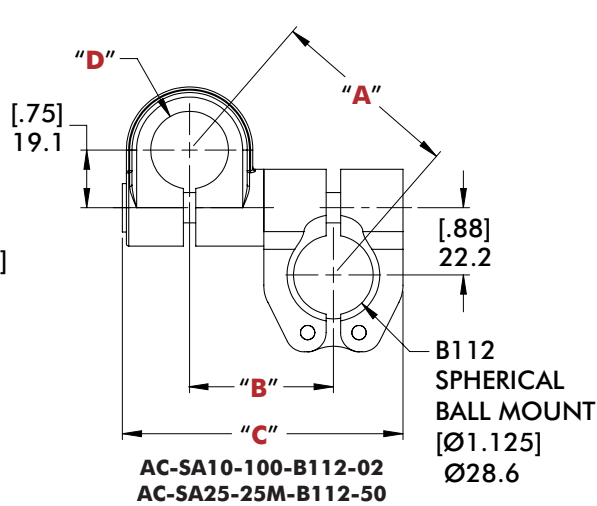
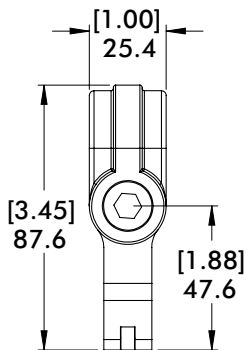

AC-SA10-100-B112-02
AC-SA25-25M-B112-50



0 degree



90 degree



180 degree



270 degree

Specifications:

Maximum Clamp Load:
111 ft-lb [150 Nm]

Material:
Aluminum

Model Number	"A"	"B"	"C"	(Ø)"D"	Weight
AC-SA10-100-B112-02	[2.48]	[1.87]	[3.65]	1.00"(in)	[0.51 lb]
AC-SA25-25M-B112-50	62.9	47.5	92.8	25mm	0.23kg
AC-SA10-100-B112-03	[3.37]	[2.95]	[4.74]	1.00"(in)	[0.59 lb]
AC-SA25-25M-B112-75	85.6	75.0	120.3	25mm	0.27kg
AC-SA10-100-B112-04	[4.26]	[3.94]	[5.72]	1.00"(in)	[0.69 lb]
AC-SA25-25M-B112-100	108.2	100.0	145.3	25mm	0.31kg
AC-SA10-100-B112-05	[5.18]	[4.92]	[6.70]	1.00"(in)	[0.78 lb]
AC-SA25-25M-B112-125	131.6	125.0	170.3	25mm	0.35 kg
AC-SA10-100-B112-06	[6.13]	[5.90]	[7.69]	1.00"(in)	[0.88 lb]
AC-SA25-25M-B112-150	155.6	150.0	195.5	25mm	0.40kg

EXTEND-ARM SWIVEL ARMS

Round Tooling | Dimensions | Technical Specifications



Features:

- Mounts apple core accessories to Ø25mm/1.00" round tube
- 50.8 [2.00] linear extension allows for precise adjustment
- Provides 360° of rotational adjustments along (3) axes
- Used to mount venturi, bumpers, round locators, and proximity switches

Specifications:

Maximum Clamp Load:
140 ft-lb [190 Nm]
Material:
Body and Insert:
Machined Aluminum
End:
Cast Aluminum

TSA Ø25mm/1.00" for Ø19mm [.75"] Apple Core

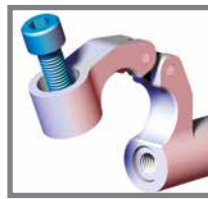
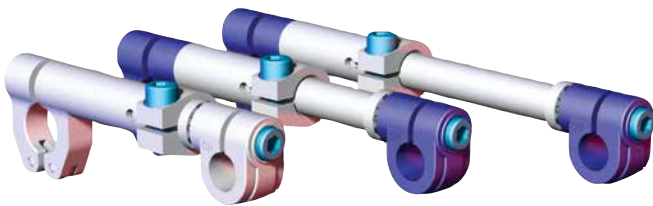

Double-hinge design allows swivel arm to be mounted directly onto boom/tube and slid into position, without having to remove existing components to slide on from boom/tube end.

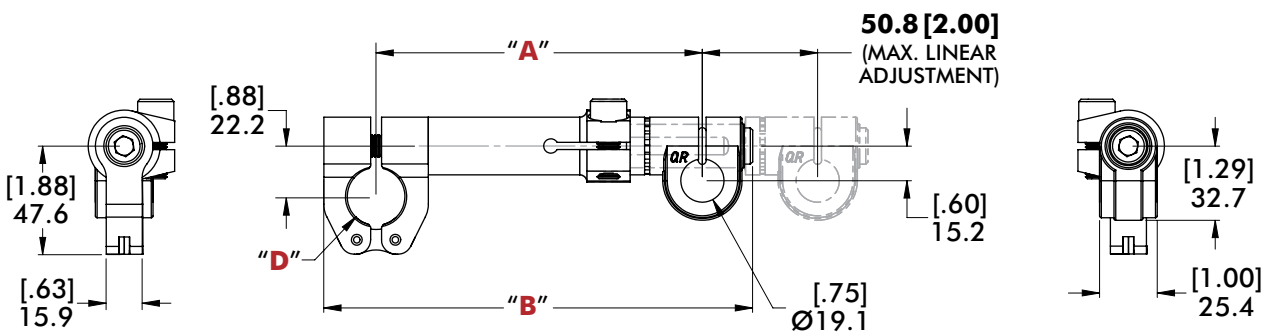
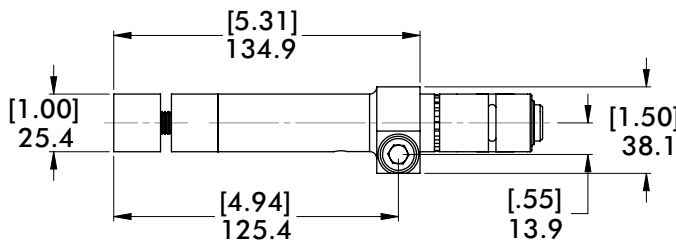

Model Number	(Ø)"D"	"A"	"B"	Weight	FINISH
CPI-55-1-TSA	1.00"(in)	[5.66]	[7.44]	[0.83 lb]	SILVER
CPI-140-25-TSA	25mm	143.7	188.9	0.38 kg	BLUE
CPI-75-1-TSA	1.00"(in)	[7.66]	[9.44]	[0.90 lb]	SILVER
CPI-190-25-TSA	25mm	194.5	239.7	0.41 kg	BLUE
CPI-95-1-TSA	1.00"(in)	[9.66]	[11.44]	[0.98 lb]	SILVER
CPI-240-25-TSA	25mm	245.3	290.5	0.44 kg	BLUE

EXTEND-ARM SWIVEL ARMS

Round Tooling | Dimensions | Technical Specifications

Features:

- Mounts apple core accessories to Ø40mm/1.50" round tube
- 50.8 [2.00] linear extension allows for precise adjustment
- Provides 360° of rotational adjustments along (3) axes
- Used to mount venturi, bumpers, round locators, and proximity switches

Specifications:

Maximum Clamp Load:
140 ft-lb [190 Nm]
Material:
Body and Insert:
Machined Aluminum
End:
Cast Aluminum

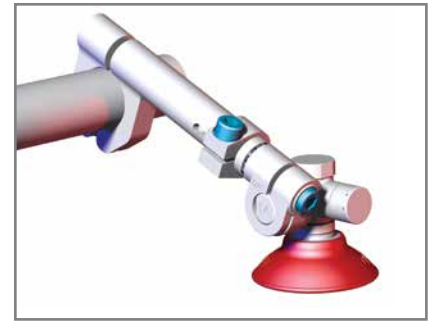

TSA Ø40mm/1.50" for Ø19mm [.75"] Apple Core



Double-hinge design allows swivel arm to be mounted directly onto boom/tube and slid into position, without having to remove existing components to slide on from boom/tube end.

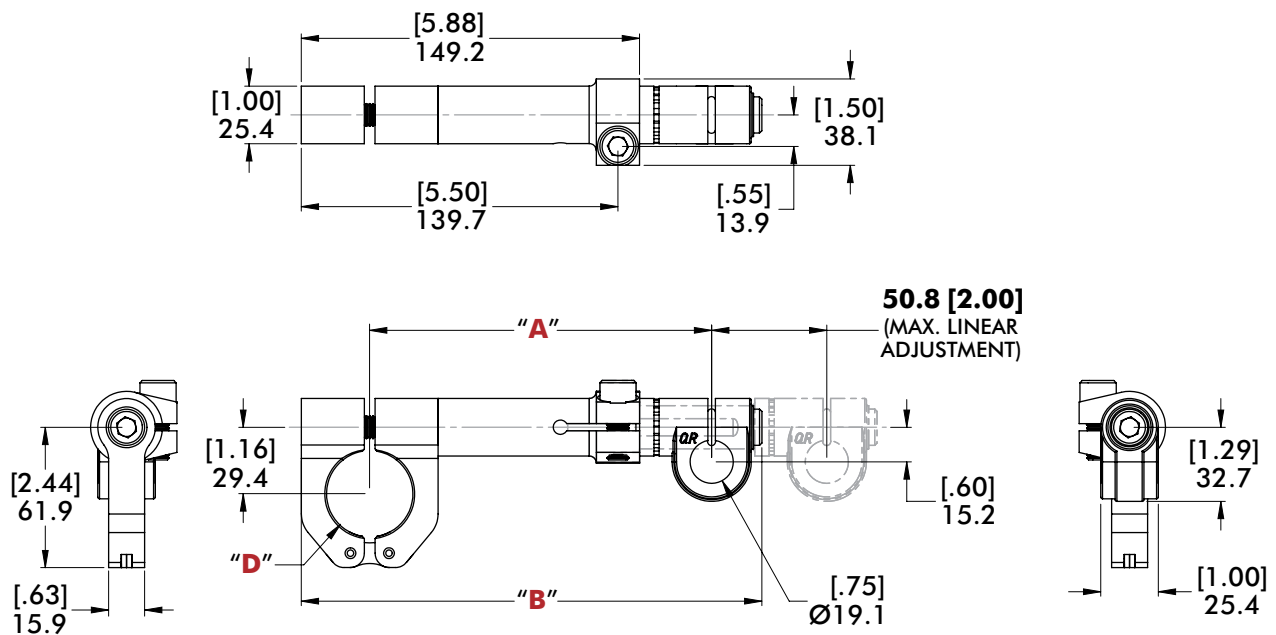
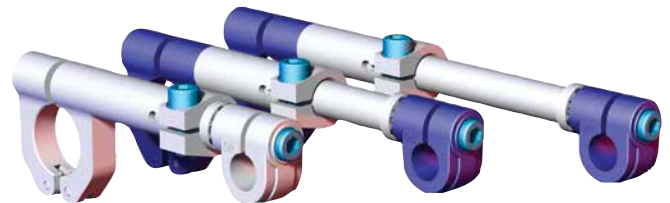

Model Number	(Ø) "D"	"A"	"B"	Weight	FINISH
CPI-55-150-TSA	1.50"(in)	[5.94]	[8.00]	[0.99 lb]	SILVER
CPI-140-40-TSA	40mm	150.9	203.2	0.45 kg	BLUE
CPI-75-150-TSA	1.50"(in)	[7.94]	[10.00]	[1.06 lb]	SILVER
CPI-190-40-TSA	40mm	201.7	254.0	0.48 kg	BLUE
CPI-95-150-TSA	1.50"(in)	[9.94]	[12.00]	[1.13 lb]	SILVER
CPI-240-40-TSA	40mm	252.5	304.8	0.51 kg	BLUE

EXTEND-ARM SWIVEL ARMS

Round Tooling | Dimensions | Technical Specifications

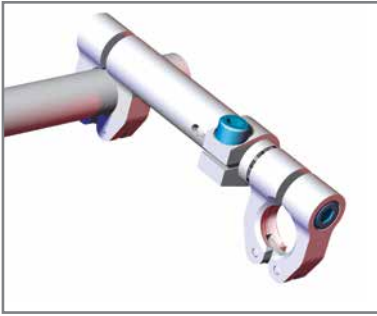

Features:

- Mounts swivel ball accessories to Ø25mm/1.00" round tube
- 50.8 [2.00] linear extension allows for precise adjustment
- Provides 360° of rotational adjustments along (3) axes
- Used to mount venturi, bumpers, round locators, and proximity switches

Specifications:

Maximum Clamp Load:
140 ft-lb [190 Nm]
Material:
Body and Insert:
Machined Aluminum
End:
Cast Aluminum

TSA-B112 Ø25mm/1.00" for Ø28.6mm [1.125"] Spherical Swivel Ball

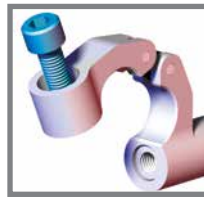
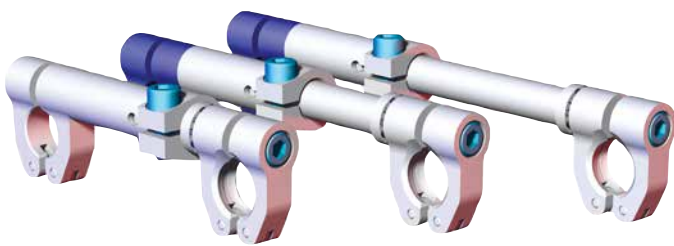

Double-hinge design allows swivel arm to be mounted directly onto boom/tube and slid into position, without having to remove existing components to slide on from boom/tube end.

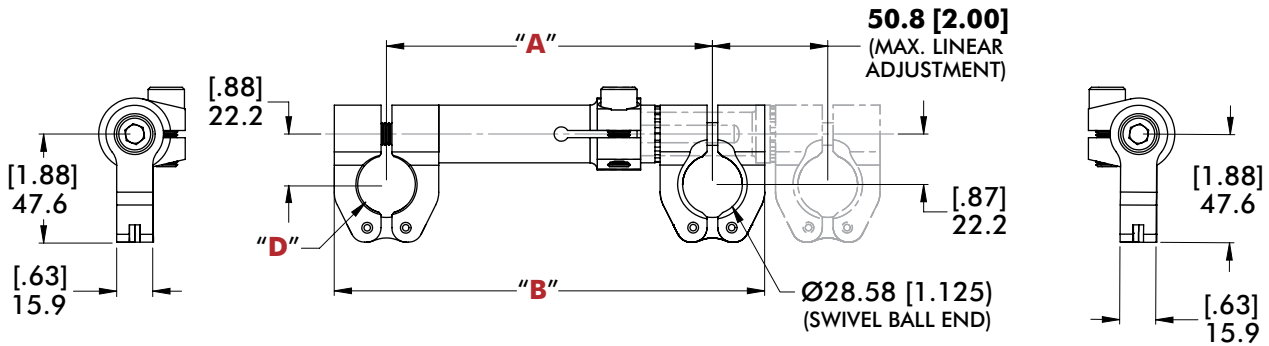
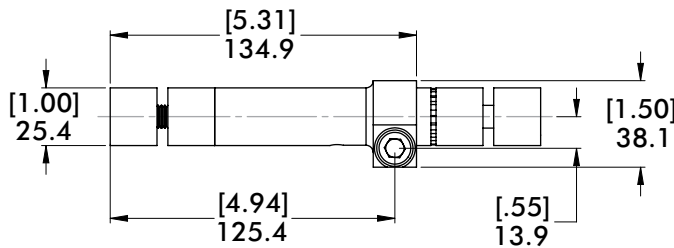

Model Number	(Ø)"D"	"A"	"B"	Weight	FINISH
CPI-55-1-TSA-B112	1.00"(in)	[5.65]	[7.47]	[0.93 lb]	SILVER
CPI-140-25-TSA-B112	25mm	143.6	189.6	0.42 kg	BLUE
CPI-75-1-TSA-B112	1.00"(in)	[7.65]	[9.47]	[1.00 lb]	SILVER
CPI-190-25-TSA-B112	25mm	194.4	240.4	0.45 kg	BLUE
CPI-95-1-TSA-B112	1.00"(in)	[9.65]	[11.47]	[1.07 lb]	SILVER
CPI-240-25-TSA-B112	25mm	245.2	291.2	0.49 kg	BLUE

EXTEND-ARM SWIVEL ARMS

Round Tooling | Dimensions | Technical Specifications

Features:

- Mounts swivel ball accessories to Ø40mm/1.50" round tube
- 50.8 [2.00] linear extension allows for precise adjustment
- Provides 360° of rotational adjustments along (3) axes
- Used to mount venturi, bumpers, round locators, and proximity switches

Specifications:

Maximum Clamp Load:
140 ft-lb [190 Nm]
Material:
Body and Insert:
Machined Aluminum
End:
Cast Aluminum

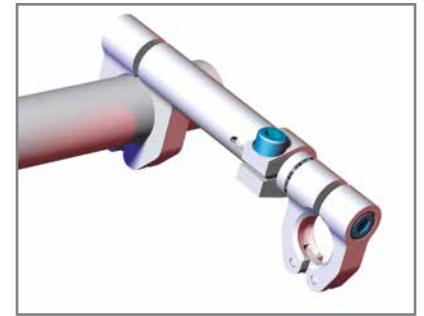

TSA-B112 Ø40mm/1.50" for Ø28.6mm [1.125"] Spherical Swivel Ball

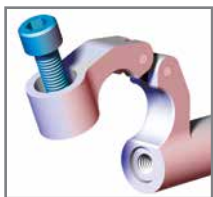

Double-hinge design allows swivel arm to be mounted directly onto boom/tube and slid into position, without having to remove existing components to slide on from boom/tube end.

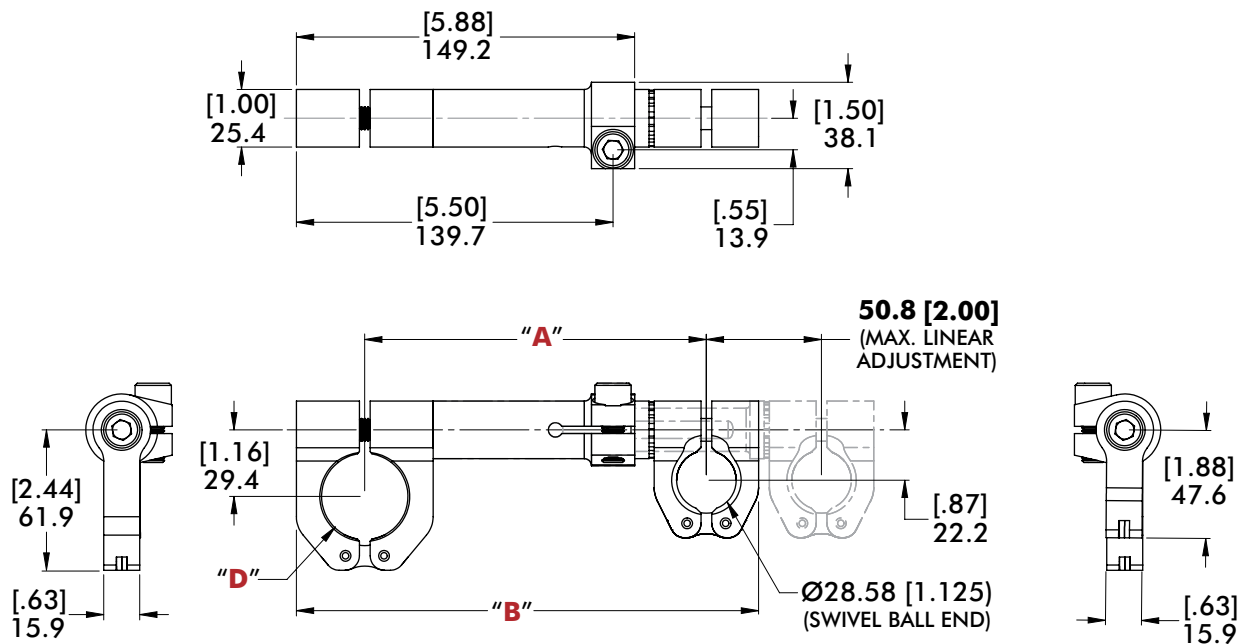
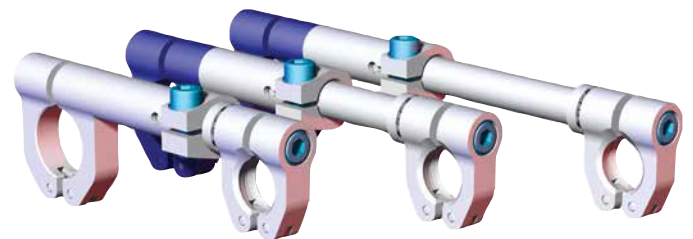

Model Number	(Ø)"D"	"A"	"B"	Weight	FINISH
CPI-55-150-TSA-B112	1.50"(in)	[5.93]	[8.03]	[1.03 lb]	SILVER
CPI-140-40-TSA-B112	40mm	150.7	203.9	0.47 kg	BLUE
CPI-75-150-TSA-B112	1.50"(in)	[7.93]	[10.03]	[1.10 lb]	SILVER
CPI-190-40-TSA-B112	40mm	201.5	254.7	0.50 kg	BLUE
CPI-95-150-TSA-B112	1.50"(in)	[9.93]	[12.03]	[1.17 lb]	SILVER
CPI-240-40-TSA-B112	40mm	252.3	305.5	0.53 kg	BLUE

MICRO TOOLING SWIVEL ARMS

Round Tooling | Dimensions | Technical Specifications

Features:

- Mounts micro apple core accessories to Ø20mm/.75" Round tube.
- Provides 360° of rotational adjustments along (3) axes.
- Used to mount venturi, bumpers, round locators, and proximity switches.

Specifications:

Maximum Clamp Load:
120 ft-lb [163 Nm]
Material:
Body and Spacer:
Machined Aluminum

Nominal (Ø) given
See chart on Page 72
for actual (Ø) size

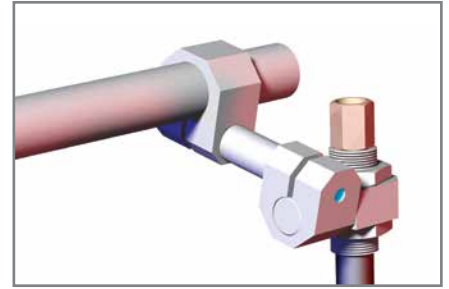

MSA Ø20mm/.75" for Ø12.7mm [.50"] Apple Core (Micro)

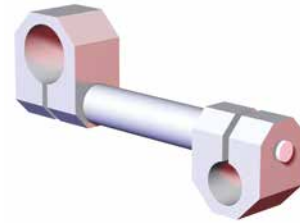
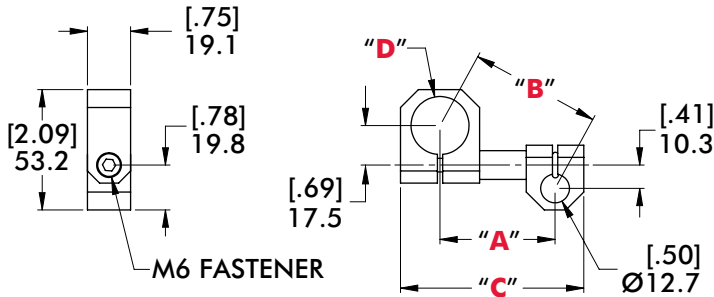

Model Number	(Ø) "D"	"A"	"B"	"C"	Weight
CPI-200-7550-MSA	.75"(in)	[2.00]	[2.28]	[3.19]	[0.16 lb]
CPI-200-20M50-MSA	20mm	50.8	57.9	81.0	0.07kg
CPI-300-7550-MSA	.75"(in)	[3.00]	[3.19]	[4.19]	[0.19 lb]
CPI-300-20M50-MSA	20mm	76.2	81.1	106.4	0.08kg
CPI-400-7550-MSA	.75"(in)	[4.00]	[4.15]	[5.19]	[0.21 lb]
CPI-400-20M50-MSA	20mm	101.7	105.4	131.9	0.09kg
CPI-500-7550-MSA	.75"(in)	[5.00]	[5.12]	[6.19]	[0.23 lb]
CPI-500-20M50-MSA	20mm	127.1	130.1	157.3	0.11kg
CPI-600-7550-MSA	.75"(in)	[6.00]	[6.10]	[7.19]	[0.26 lb]
CPI-600-20M50-MSA	20mm	152.5	155.0	182.7	0.12kg

MICRO TOOLING SWIVEL ARMS

Nominal (Ø) given
See chart on Page 72
for actual (Ø) size

Round Tooling | Dimensions | Technical Specifications

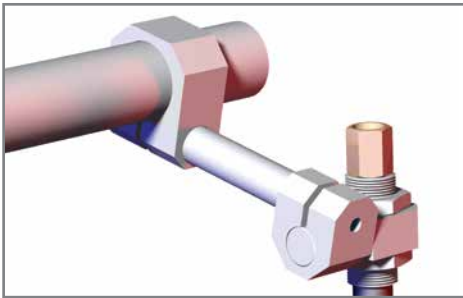

Features:

- Mounts micro apple core accessories to Ø25mm/1.00" Round tube
- Provides 360° of rotational adjustments along (3) axes
- Used to mount venturi, bumpers, round locators, and proximity switches

Specifications:

Maximum Clamp Load:
120 ft-lb [163 Nm]
Material:
Body and Spacer:
Machined Aluminum

MSA Ø25mm/1.00" for Ø12.7mm [.50"] Apple Core (Micro)

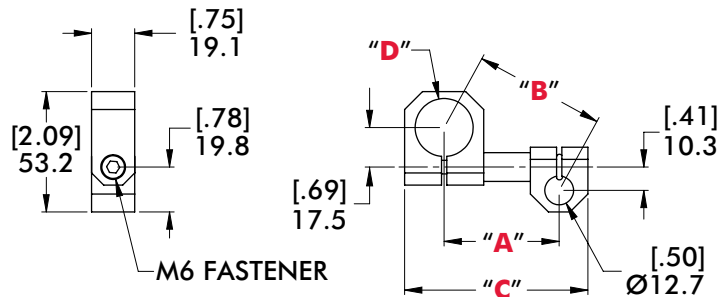
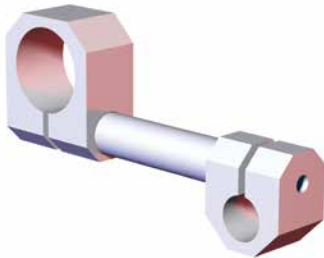

Model Number	(Ø)"D"	"A"	"B"	"C"	Weight
CPI-200-1050-MSA	1.00"(in)	[2.00]	[2.23]	[3.06]	[0.18 lb]
CPI-200-25M50-MSA	25mm	50.7	56.6	77.7	0.08kg
CPI-300-1050-MSA	1.00"(in)				
CPI-300-25M50-MSA	25mm	[3.00]	[3.16]	[4.11]	[0.21 lb]
CPI-300-30B50-MSA	30mm	76.1	80.2	104.4	0.09kg
CPI-400-1050-MSA	1.00"(in)				
CPI-400-25M50-MSA	25mm	[4.00]	[4.12]	[5.08]	[0.23 lb]
CPI-400-30B50-MSA	30mm	101.6	104.7	129.0	0.10kg
CPI-500-1050-MSA	1.00"(in)				
CPI-500-25M50-MSA	25mm	[5.00]	[5.10]	[6.14]	[0.25 lb]
CPI-500-30B50-MSA	30mm	127.0	129.5	156.0	0.11kg
CPI-600-1050-MSA	1.00"(in)				
CPI-600-25M50-MSA	25mm	[6.00]	[6.08]	[7.09]	[0.27 lb]
CPI-600-30B50-MSA	30mm	152.4	154.4	180.0	0.13kg

STANDARD SWIVEL ARMS

Round Tooling | Dimensions | Technical Specifications



Features:

- Mounts apple core accessories to Ø25mm/1.00" round tube
- Provides 360° of rotational adjustments along (3) axes
- Used to mount venturi, bumpers, round locators, and proximity switches

Specifications:

Maximum Clamp Load:
200 ft-lb [271 Nm]
Material:
Body:
Cast Aluminum
Spacer:
Machined Aluminum

SA Ø25mm/1.00" for Ø19.1mm [.75"] Apple Core

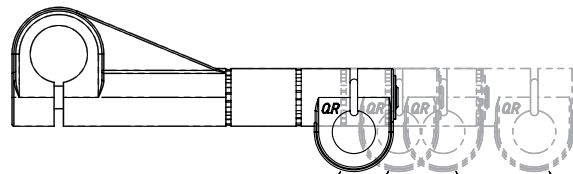

CPI-500-XX-SA

CPI-800-XX-SA

CPI-600-XX-SA

CPI-700-XX-SA

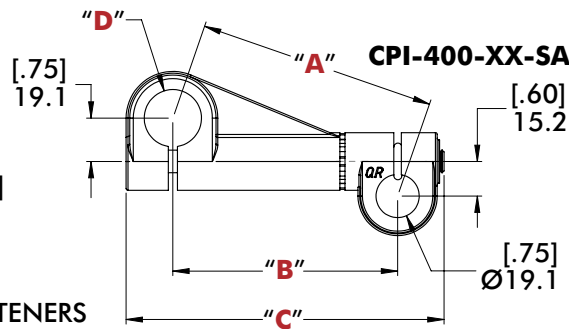
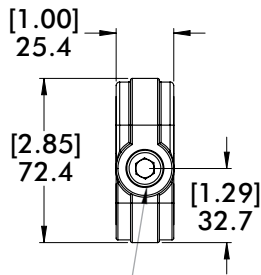

Model Number	(Ø)"D"	"A"	"B"	"C"	Weight	FINISH
CPI-400-1-SA	1.00"(in)	[4.13]	[3.90]	[5.52]	[0.70 lb]	SILVER
CPI-100-25-SA	25mm	104.9	99.1	140.2	0.31 kg	BLUE
CPI-500-1-SA	1.00"(in)	[5.30]	[5.12]	[6.70]	[0.82 lb]	SILVER
CPI-140-25-SA	25mm	134.5	130.1	170.2	0.37 kg	BLUE
CPI-600-1-SA	1.00"(in)	[6.05]	[5.90]	[7.49]	[0.90 lb]	SILVER
CPI-160-25-SA	25mm	153.8	149.9	190.2	0.41 kg	BLUE
CPI-700-1-SA	1.00"(in)	[6.81]	[6.67]	[8.27]	[0.97 lb]	SILVER
CPI-180-25-SA	25mm	172.9	169.4	210.2	0.44 kg	BLUE
CPI-800-1-SA	1.00"(in)	[8.36]	[8.25]	[9.85]	[1.13 lb]	SILVER
CPI-200-25-SA	25mm	212.4	209.6	250.2	0.51 kg	BLUE

STANDARD SWIVEL ARMS

Round Tooling | Dimensions | Technical Specifications

Features:

- Mounts apple core accessories to Ø40mm/1.50" round tube
- Provides 360° of rotational adjustments along (3) axes
- Used to mount venturi, bumpers, round locators, and proximity switches

Specifications:

Maximum Clamp Load:
200 ft-lb [271 Nm]
Material:
Body:
Cast Aluminum
Spacer:
Machined Aluminum



SA Ø40mm/1.50" for Ø19.1mm [.75"] Apple Core

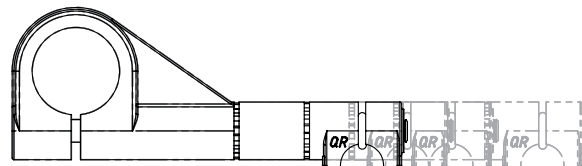
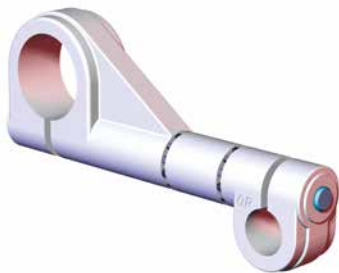

CPI-500-XX-SA CPI-800-XX-SA
CPI-600-XX-SA CPI-700-XX-SA

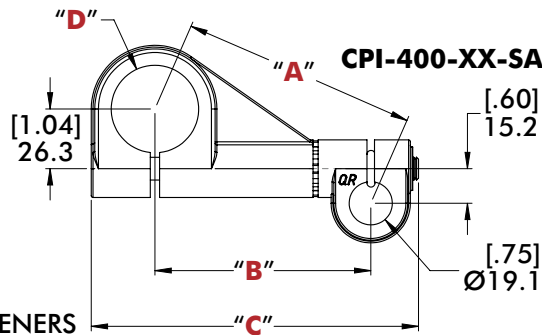
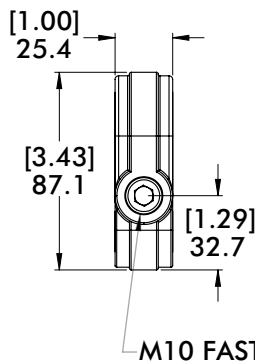

Model Number	(Ø)"D"	"A"	"B"	"C"	Weight	FINISH
CPI-400-15-SA	1.50"(in)	[4.09]	[3.75]	[5.68]	[0.78 lb]	SILVER
CPI-100-40-SA	40mm	103.8	95.2	144.3	0.35 kg	BLUE
CPI-500-15-SA	1.50"(in)	[5.23]	[4.97]	[6.86]	[0.89 lb]	SILVER
CPI-140-40-SA	40mm	132.8	126.1	174.3	0.41 kg	BLUE
CPI-600-15-SA	1.50"(in)	[5.97]	[5.75]	[7.65]	[0.97 lb]	SILVER
CPI-160-40-SA	40mm	151.8	146.0	194.3	0.44 kg	BLUE
CPI-700-15-SA	1.50"(in)	[6.72]	[6.52]	[8.44]	[1.05 lb]	SILVER
CPI-180-40-SA-SA	40mm	170.7	165.5	214.3	0.54 kg	BLUE
CPI-800-15-SA	1.50"(in)	[8.26]	[8.10]	[10.01]	[1.20 lb]	SILVER
CPI-200-40-SA	40mm	209.8	205.6	2.54	0.55 kg	BLUE

STANDARD SWIVEL ARMS

Round Tooling | Dimensions | Technical Specifications

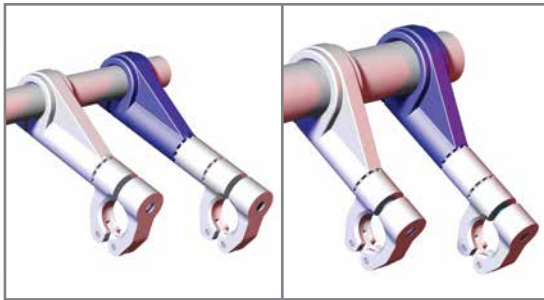

Features:

- Mounts swivel ball accessories to round tube
- Provides 360° of rotational adjustments along (3) axes
- Used to mount venturi, bumpers, round locators, and proximity switches

Specifications:

Maximum Clamp Load:
200 ft-lb [271 Nm]
Material:
Body:
Cast Aluminum
Spacer:
Machined Aluminum

SA-B112 Ø25mm/1.00" for Ø28.6mm [1.125"] Spherical Swivel Ball

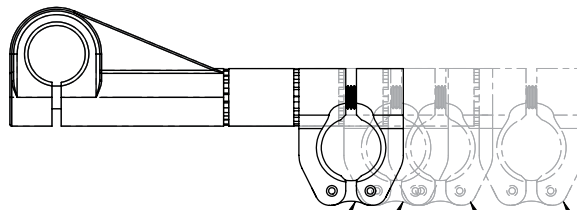
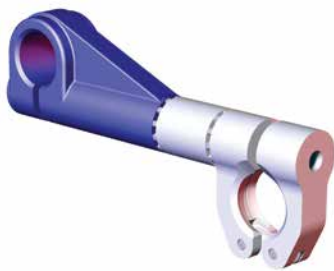

CPI-500-XX-SA-B112

CPI-800-XX-SA-B112

CPI-600-XX-SA-B112

CPI-700-XX-SA-B112

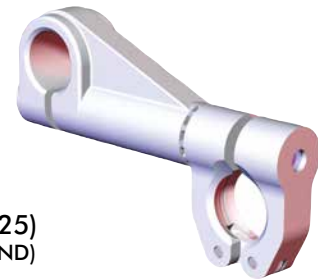
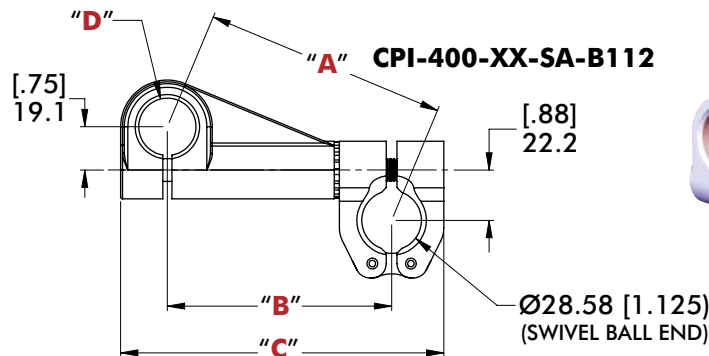
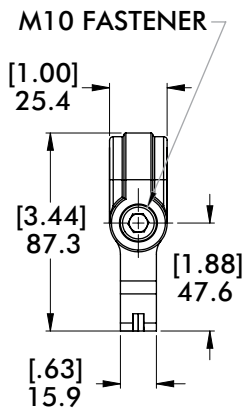

Model Number	(Ø)"D"	"A"	"B"	"C"	Weight	FINISH
CPI-400-1-SA-B112	1.00"(in)	[4.22]	[3.90]	[5.61]	[0.74 lb]	SILVER
CPI-100-25-SA-B112	25mm	107.2	98.9	142.6	0.34 kg	BLUE
CPI-500-1-SA-B112	1.00"(in)	[5.37]	[5.12]	[6.83]	[0.86 lb]	SILVER
CPI-140-25-SA-B112	25mm	136.3	129.9	173.5	0.39 kg	BLUE
CPI-600-1-SA-B112	1.00"(in)	[6.12]	[5.90]	[7.61]	[0.94 lb]	SILVER
CPI-160-25-SA-B112	25mm	155.3	149.7	193.4	0.43 kg	BLUE
CPI-700-1-SA-B112	1.00"(in)	[6.86]	[6.67]	[8.38]	[1.02 lb]	SILVER
CPI-180-25-SA-B112	25mm	174.3	169.3	212.9	0.46 kg	BLUE
CPI-800-1-SA-B112	1.00"(in)	[8.40]	[8.25]	[9.96]	[1.17 lb]	SILVER
CPI-200-25-SA-B112	25mm	213.5	209.4	253.0	0.53 kg	BLUE

STANDARD SWIVEL ARMS

Round Tooling | Dimensions | Technical Specifications

SA-B112 Ø40mm/1.50" for Ø28.6mm [1.125"] Spherical Swivel Ball

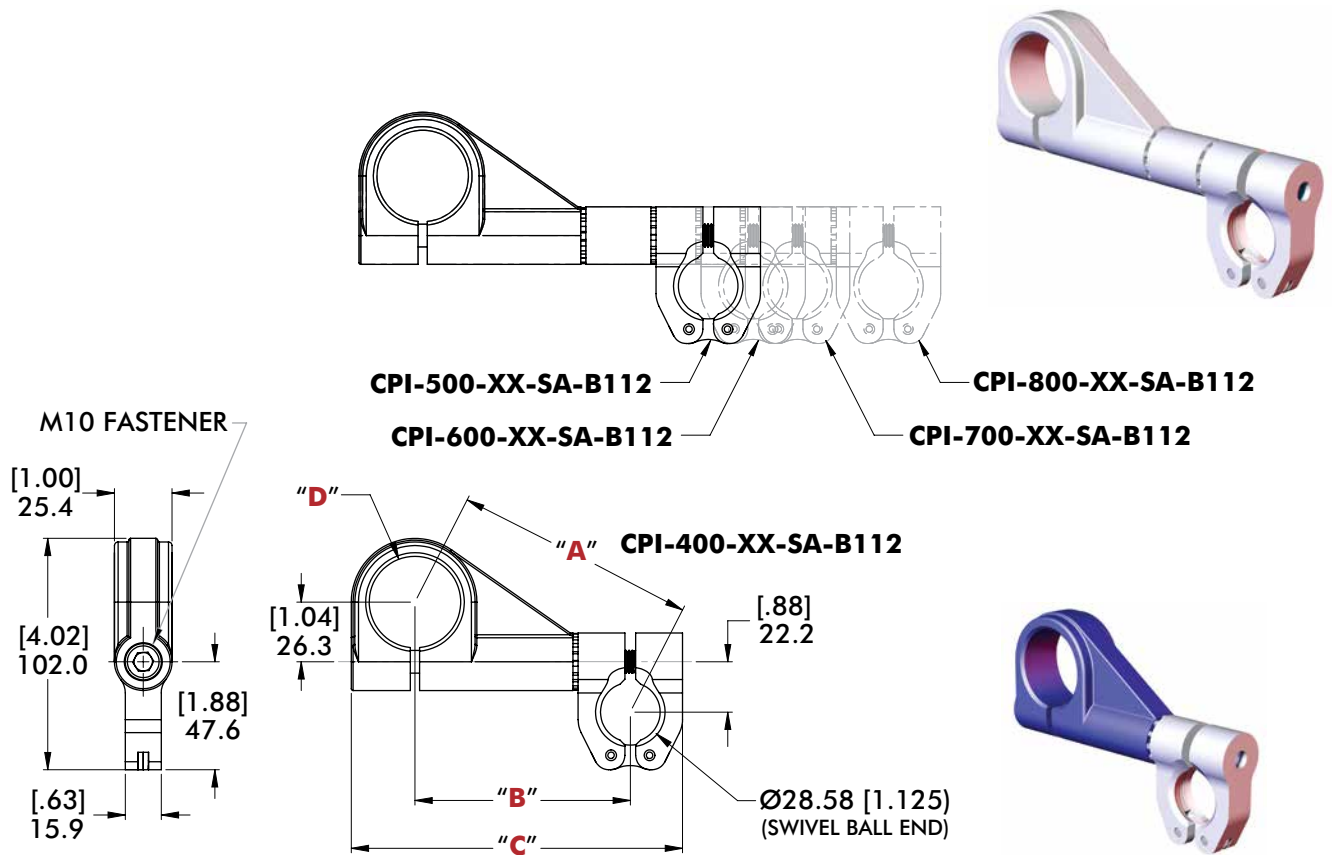

Model Number	(Ø)"D"	"A"	"B"	"C"	Weight	FINISH
CPI-400-15-SA-B112	1.50"(in)	[4.20]	[3.74]	[5.75]	[0.82 lb]	SILVER
CPI-100-40-SA-B112	40mm	106.7	95.0	146.1	0.37 kg	BLUE
CPI-500-15-SA-B112	1.50"(in)	[5.32]	[4.96]	[6.97]	[0.94 lb]	SILVER
CPI-140-40-SA-B112	40mm	135.0	126.0	177.1	0.42 kg	BLUE
CPI-600-15-SA-B112	1.50"(in)	[6.05]	[5.74]	[7.75]	[1.02 lb]	SILVER
CPI-160-40-SA-B112	40mm	153.7	145.8	196.9	0.46 kg	BLUE
CPI-700-15-SA-B112	1.50"(in)	[6.78]	[6.51]	[8.52]	[1.09 lb]	SILVER
CPI-180-40-SA-B112	40mm	172.3	165.4	216.5	0.50 kg	BLUE
CPI-800-15-SA-B112	1.50"(in)	[8.31]	[8.09]	[10.10]	[1.25 lb]	SILVER
CPI-200-40-SA-B112	40mm	211.1	205.5	256.6	0.56 kg	BLUE

STANDARD SWIVEL ARMS

Round Tooling | Dimensions | Technical Specifications



Features:

- Mounts apple core accessories to Ø25mm/1.00" round tube
- Provides 360° of rotational adjustments along (3) axes
- Used to mount venturi, bumpers, round locators, and proximity switches

Specifications:

Maximum Clamp Load:
200 ft-lb [271 Nm]
Material:
Body:
Cast Aluminum
Spacer:
Machined Aluminum

S_{Axx} Single-Bolt Ø25mm/1.00" for Ø19.1mm [.75"] Apple Core

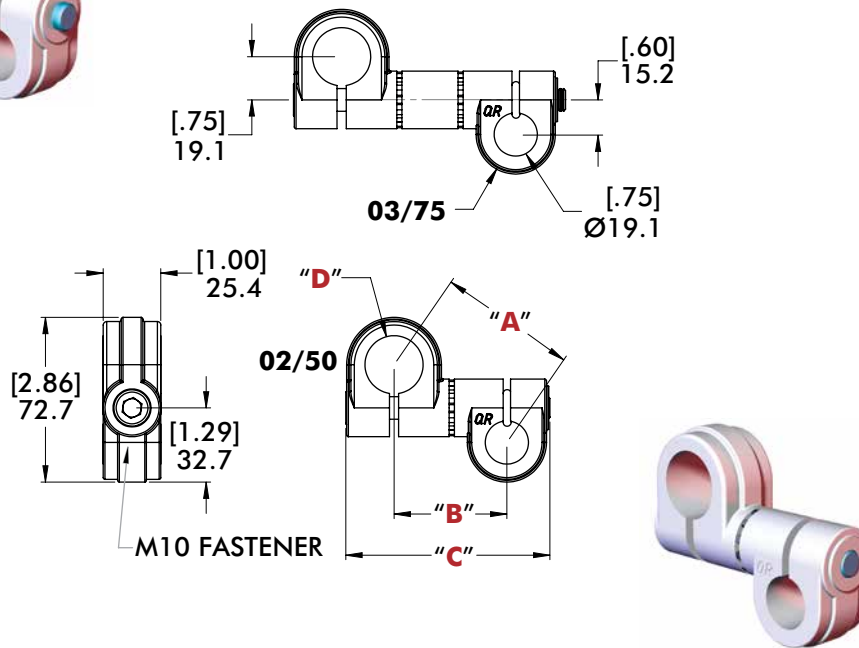

Model Number	(Ø)"D"	"A"	"B"	"C"	Weight	FINISH
CPI-SA10-100-075-02	1.00"(in)	[2.38]	[1.96]	[3.54]	[0.46 lb]	SILVER
CPI-SA25-25-19-50	25mm	60.4	49.8	90.0	0.21 kg	BLUE
CPI-SA10-100-075-03	1.00"(in)	[3.31]	[3.02]	[4.72]	[0.57 lb]	SILVER
CPI-SA25-25-19-75	25mm	84.1	76.8	120.0	0.26 kg	BLUE

STANDARD SWIVEL ARMS

Round Tooling | Dimensions | Technical Specifications

EDxx Double-Bolt Ø25mm/1.00" for Ø19.1mm [.75"] Apple Core

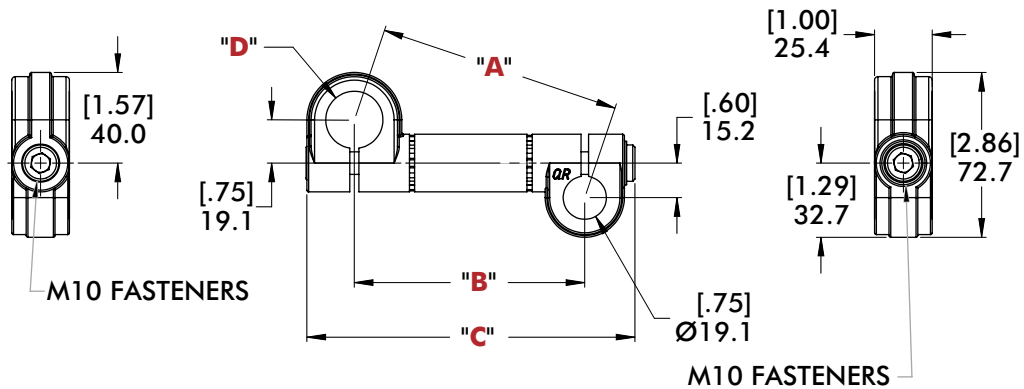

Model Number	(Ø)"D"	"A"	"B"	"C"	Weight	FINISH
CPI-ED10-100-075-04	1.00"(in)	[4.27] 108.4	[4.05] 102.9	[5.74] 145.9	[0.65 lb] 0.29 kg	SILVER
CPI-ED25-25-19-100	25mm	[4.22] 107.2	[4.00] 101.6	[5.69] 144.6		BLUE
CPI-ED10-100-075-05	1.00"(in)	[5.23] 132.8	[5.05] 128.3	[6.74] 171.3	[0.71 lb] 0.32 kg	SILVER
CPI-ED10-100-075-06	1.00"(in)	[6.20] 157.4	[6.05] 153.7	[7.74] 196.7	[0.78 lb] 0.36 kg	SILVER
CPI-ED25-25-19-150	25mm	[6.13] 155.7	[5.98] 151.9	[7.67] 194.2		BLUE
CPI-ED10-100-075-07	1.00"(in)	[7.18] 182.3	[7.05] 179.1	[8.74] 222.1	[0.85 lb] 0.39 kg	SILVER
CPI-ED10-100-075-08	1.00"(in)	[8.16] 207.3	[8.05] 204.5	[9.74] 247.5	[0.92 lb] 0.42 kg	SILVER
CPI-ED25-25-19-200	25mm	[8.06] 204.8	[7.95] 201.9	[9.64] 244.9		BLUE
CPI-ED10-100-075-09	1.00"(in)	[9.15] 232.4	[9.05] 229.9	[10.74] 272.9	[0.99 lb] 0.45 kg	SILVER
CPI-ED10-100-075-10	1.00"(in)	[10.14] 257.6	[10.05] 255.3	[11.74] 298.3	[1.06 lb] 0.48 kg	SILVER
CPI-ED25-25-19-250	25mm	[10.01] 254.3	[9.92] 252.0	[11.61] 295.0		BLUE
CPI-ED10-100-075-11	1.00"(in)	[11.13] 282.7	[11.05] 280.7	[12.74] 323.7	[1.13 lb] 0.51 kg	SILVER
CPI-ED10-100-075-12	1.00"(in)	[12.13] 308.0	[12.05] 306.1	[13.74] 349.0	[1.20 lb] 0.54 kg	SILVER
CPI-ED25-25-19-300	25mm	[11.97] 303.9	[11.89] 302.0	[13.58] 345.0		BLUE
CPI-ED10-100-075-13	1.00"(in)	[13.12] 338.2	[13.05] 331.5	[14.74] 374.5	[1.27 lb] 0.58 kg	SILVER
CPI-ED10-100-075-14	1.00"(in)	[14.11] 358.5	[14.05] 356.9	[15.74] 399.9	[1.34 lb] 0.61 kg	SILVER
CPI-ED25-25-19-350	25mm	[13.92] 353.4	[13.85] 351.8	[15.54] 394.8		BLUE
CPI-ED10-100-075-15	1.00"(in)	[15.11] 383.8	[15.05] 382.3	[16.74] 425.3	[1.41 lb] 0.64 kg	SILVER
CPI-ED10-100-075-16	1.00"(in)	[16.11] 409.1	[16.05] 407.7	[17.74] 450.7	[1.48 lb] 0.67 kg	SILVER
CPI-ED25-25-19-400	25mm	[15.88] 403.3	[15.82] 401.8	[17.51] 444.9		BLUE

STANDARD SWIVEL ARMS

Round Tooling | Dimensions | Technical Specifications



Features:

- Mounts apple core accessories to Ø40mm/1.50" round tube
- Provides 360° of rotational adjustments along (3) axes
- Used to mount venturi, bumpers, round locators, and proximity switches

Specifications:

Maximum Clamp Load:
200 ft-lb [271 Nm]
Material:
Body:
Cast Aluminum
Spacer:
Machined Aluminum

SAxx Single-Bolt Ø40mm/1.50" for Ø19.1mm [.75"] Apple Core

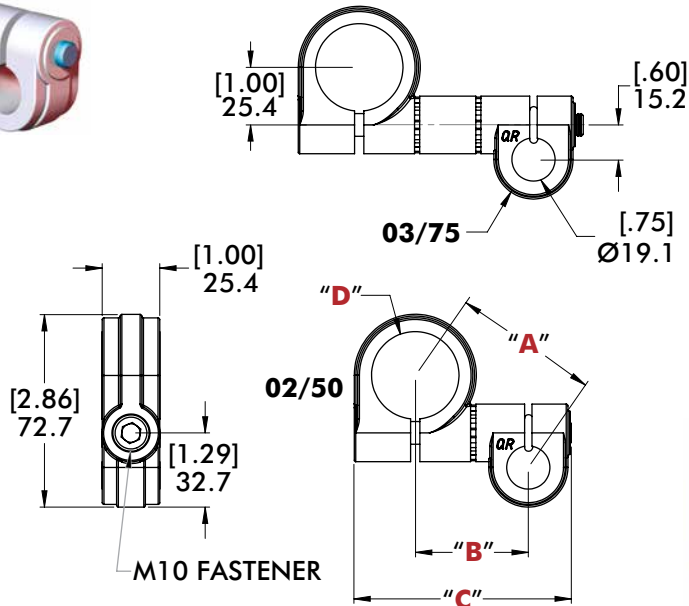

Model Number	(Ø) "D"	"A"	"B"	"C"	Weight	FINISH
CPI-SA10-150-075-02	1.50"(in)	[2.53]	[1.96]	[3.77]	[0.50 lb]	SILVER
CPI-SA25-40-19-50	40mm	64.3	49.8	95.9	0.23 kg	BLUE
CPI-SA10-150-075-03	1.50"(in)	[3.42]	[3.03]	[4.95]	[0.62 lb]	SILVER
CPI-SA25-40-19-75	40mm	87.0	76.9	125.9	0.28 kg	BLUE

STANDARD SWIVEL ARMS

Round Tooling | Dimensions | Technical Specifications

EDxx Double-Bolt Ø40mm/1.50" for Ø19.1mm [.75"] Apple Core

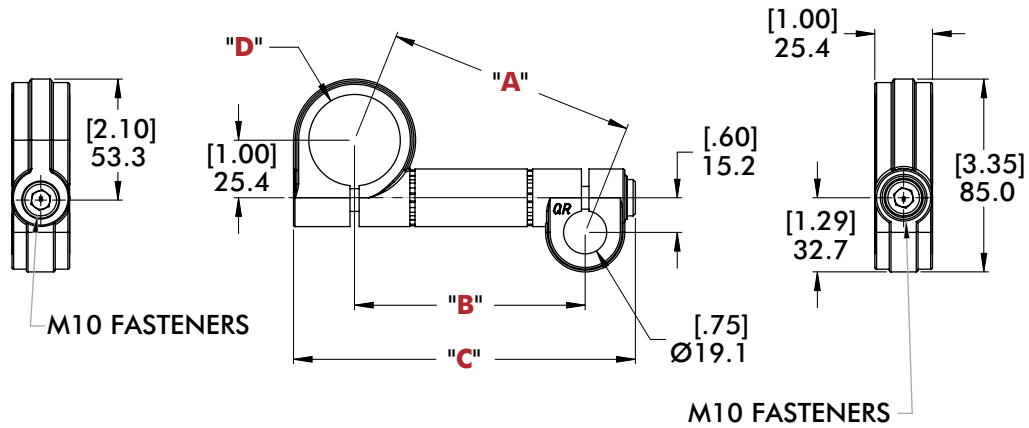

Model Number	(Ø)"D"	"A"	"B"	"C"	Weight	FINISH
CPI-ED10-150-075-04	1.50"(in)	[4.36] 110.7	[4.05] 102.9	[5.98] 152.0	[0.69 lb] 0.31 kg	SILVER
CPI-ED25-40-19-100	40mm	[4.31] 109.5	[4.00] 101.7	[5.93] 150.7	0.31 kg	BLUE
CPI-ED10-150-075-05	1.50"(in)	[5.30] 134.6	[5.05] 128.3	[6.98] 177.4	[0.76 lb] 0.34 kg	SILVER
CPI-ED10-150-075-06	1.50"(in)	[6.26] 159.0	[6.05] 153.7	[7.98] 202.8	[0.83 lb] 0.38 kg	SILVER
CPI-ED25-40-19-150	40mm	[6.19] 157.3	[5.98] 152.0	[7.91] 201.0	0.38 kg	BLUE
CPI-ED10-150-075-07	1.50"(in)	[7.23] 183.7	[7.05] 179.1	[8.98] 228.2	[0.90 lb] 0.41 kg	SILVER
CPI-ED10-150-075-08	1.50"(in)	[8.21] 208.5	[8.05] 204.5	[9.98] 253.6	[0.97 lb] 0.44 kg	SILVER
CPI-ED25-40-19-200	40mm	[8.11] 206.0	[7.95] 202.0	[9.88] 251.0	0.44 kg	BLUE
CPI-ED10-150-075-09	1.50"(in)	[9.19] 233.5	[9.05] 229.9	[10.98] 279.0	[1.03 lb] 0.47 kg	SILVER
CPI-ED10-150-075-10	1.50"(in)	[10.18] 258.5	[10.05] 255.3	[11.98] 304.4	[1.10 lb] 0.50 kg	SILVER
CPI-ED25-40-19-250	40mm	[10.05] 255.3	[9.92] 252.0	[11.85] 308.1	0.50 kg	BLUE
CPI-ED10-150-075-11	1.50"(in)	[11.17] 283.7	[11.05] 280.7	[12.98] 329.8	[1.17 lb] 0.53 kg	SILVER
CPI-ED10-150-075-12	1.50"(in)	[12.16] 308.8	[12.05] 306.1	[13.98] 355.2	[1.24 lb] 0.56 kg	SILVER
CPI-ED25-40-19-300	40mm	[12.00] 304.8	[11.89] 302.1	[13.82] 351.1	0.56 kg	BLUE
CPI-ED10-150-075-13	1.50"(in)	[13.15] 334.0	[13.05] 331.5	[14.98] 380.6	[1.31 lb] 0.59 kg	SILVER
CPI-ED10-150-075-14	1.50"(in)	[14.14] 359.2	[14.05] 356.9	[15.98] 406.0	[1.38 lb] 0.63 kg	SILVER
CPI-ED25-40-19-350	40mm	[13.94] 354.2	[13.85] 351.9	[15.78] 400.9	0.63 kg	BLUE
CPI-ED10-150-075-15	1.50"(in)	[15.14] 384.5	[15.05] 382.3	[16.98] 431.4	[1.45 lb] 0.66 kg	SILVER
CPI-ED10-150-075-16	1.50"(in)	[16.13] 409.8	[16.05] 407.7	[17.98] 456.8	[1.52 lb] 0.69 kg	SILVER
CPI-ED25-40-19-400	40mm	[15.90] 403.9	[15.82] 401.9	[18.00] 450.9	0.69 kg	BLUE

TRANSITION SWIVEL ARMS

Round Tooling | Dimensions | Technical Specifications

SAxx Single-Bolt Ø25mm/1.00" to 25mm/Ø1.00"

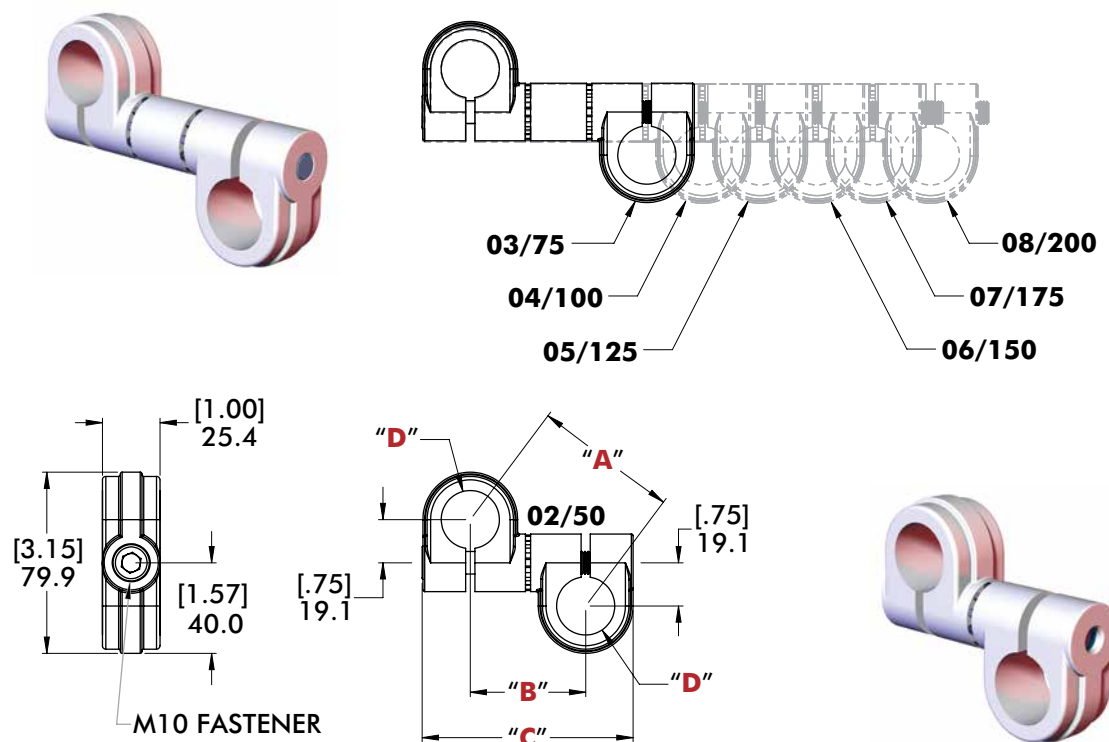

Model Number	(Ø)"D"	"A"	"B"	"C"	Weight	FINISH
CPI-SA10-100-100-02	1.00"(in)	[2.50]	[2.00]	[3.66]	[0.49 lb]	SILVER
CPI-SA25-25-25-50	25mm	63.6	50.9	93.1	0.22 kg	BLUE
CPI-SA10-100-100-03	1.00"(in)	[3.42]	[3.07]	[4.73]	[0.60 lb]	SILVER
CPI-SA25-25-25-75	25mm	86.7	77.9	120.1	0.27 kg	BLUE
CPI-SA10-100-100-04	1.00"(in)	[4.31]	[4.04]	[5.70]	[0.69 lb]	SILVER
CPI-SA25-25-25-100	25mm	109.6	102.7	144.9	0.31 kg	BLUE
CPI-SA10-100-100-05	1.00"(in)	[5.25]	[5.03]	[6.69]	[0.79 lb]	SILVER
CPI-SA25-25-25-125	25mm	133.4	127.9	170.0	0.36 kg	BLUE
CPI-SA10-100-100-06	1.00"(in)	[6.21]	[6.02]	[7.68]	[0.88 lb]	SILVER
CPI-SA25-25-25-150	25mm	157.7	153.0	195.2	0.40 kg	BLUE
CPI-SA10-100-100-07	1.00"(in)	[7.16]	[7.00]	[9.06]	[1.00 lb]	SILVER
CPI-SA25-25-25-175	25mm	181.9	177.9	230.0	0.45 kg	BLUE
CPI-SA10-100-100-08	1.00"(in)	[8.13]	[7.99]	[9.84]	[1.09 lb]	SILVER
CPI-SA25-25-25-200	25mm	206.6	203.0	250.0	0.50 kg	BLUE

TRANSITION SWIVEL ARMS

Round Tooling | Dimensions | Technical Specifications

EDxx Double-Bolt Ø25mm/1.00" to Ø25mm/1.00"

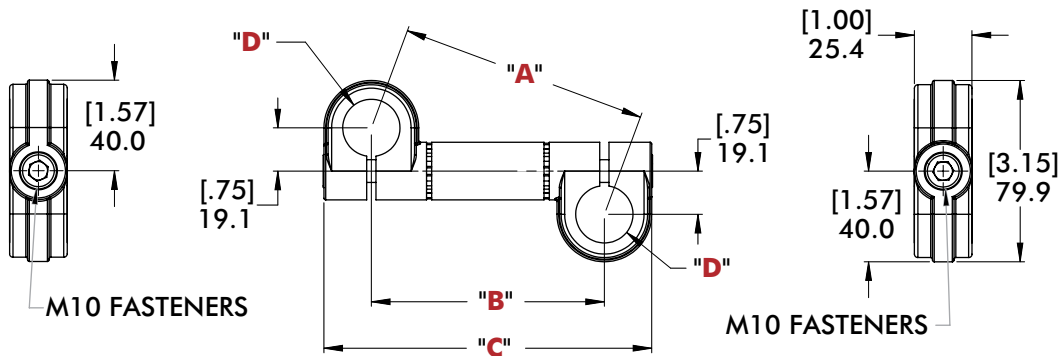

Model Number	(Ø)"D"	"A"	"B"	"C"	Weight	FINISH
CPI-ED10-100-100-04	1.00"(in)	[4.36] 110.7	[4.09] 104.0	[5.74] 145.8	[0.67 lb] 0.30 kg	SILVER
CPI-ED25-25-25-100	25mm	[4.31] 109.6	[4.04] 102.7	[5.69] 144.5		BLUE
CPI-ED10-100-100-05	1.00"(in)	[5.31] 134.9	[5.09] 129.4	[6.74] 171.2	[0.74 lb] 0.34 kg	SILVER
CPI-ED10-100-100-06	1.00"(in)	[6.28] 159.4	[6.09] 154.8	[7.74] 196.6	[0.81 lb] 0.37 kg	SILVER
CPI-ED25-25-25-150	25mm	[6.21] 157.7	[6.02] 153.0	[7.67] 194.8		BLUE
CPI-ED10-100-100-07	1.00"(in)	[7.25] 184.2	[7.09] 180.2	[8.74] 222.0	[0.88 lb] 0.40 kg	SILVER
CPI-ED10-100-100-08	1.00"(in)	[8.23] 209.1	[8.09] 205.6	[9.74] 247.4	[0.95 lb] 0.43 kg	SILVER
CPI-ED25-25-25-200	25mm	[8.13] 206.6	[7.99] 203.0	[9.64] 244.9		BLUE
CPI-ED10-100-100-09	1.00"(in)	[9.22] 234.1	[9.09] 231.0	[10.74] 272.8	[1.02 lb] 0.46 kg	SILVER
CPI-ED10-100-100-10	1.00"(in)	[10.20] 259.2	[10.09] 256.4	[11.74] 298.2	[1.09 lb] 0.49 kg	SILVER
CPI-ED25-25-25-250	25mm	[10.08] 255.9	[9.96] 253.1	[11.61] 294.9		BLUE
CPI-ED10-100-100-11	1.00"(in)	[11.19] 284.4	[11.09] 281.8	[12.74] 323.6	[1.15 lb] 0.52 kg	SILVER
CPI-ED10-100-100-12	1.00"(in)	[12.19] 309.5	[12.09] 307.2	[13.74] 349.0	[1.22 lb] 0.56 kg	SILVER
CPI-ED25-25-25-300	25mm	[12.03] 305.5	[11.93] 303.1	[13.58] 344.9		BLUE
CPI-ED10-100-100-13	1.00"(in)	[13.18] 334.8	[13.09] 332.6	[14.74] 374.4	[1.29 lb] 0.59 kg	SILVER
CPI-ED10-100-100-14	1.00"(in)	[14.17] 360.0	[14.09] 358.0	[15.74] 399.8	[1.36 lb] 0.62 kg	SILVER
CPI-ED25-25-25-350	25mm	[13.97] 355.0	[13.89] 352.9	[15.54] 394.7		BLUE
CPI-ED10-100-100-15	1.00"(in)	[15.17] 385.3	[15.09] 383.4	[16.74] 425.2	[1.43 lb] 0.65 kg	SILVER
CPI-ED10-100-100-16	1.00"(in)	[16.16] 410.6	[16.09] 408.8	[17.74] 450.6	[1.50 lb] 0.68 kg	SILVER
CPI-ED25-25-25-400	25mm	[15.93] 404.7	[15.86] 402.9	[17.51] 444.8		BLUE

TRANSITION SWIVEL ARMS

Round Tooling | Dimensions | Technical Specifications

SAxx Single-Bolt Ø40mm/1.50" to Ø25mm/1.00"

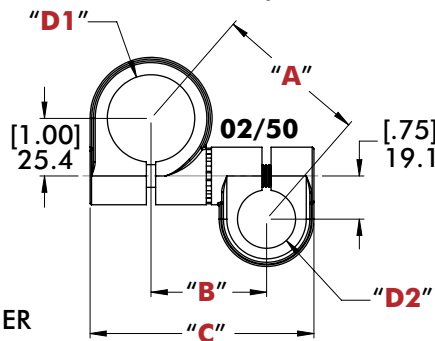
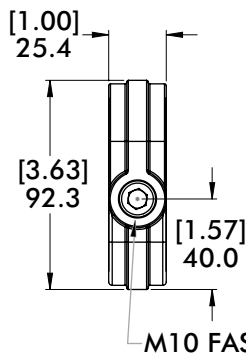
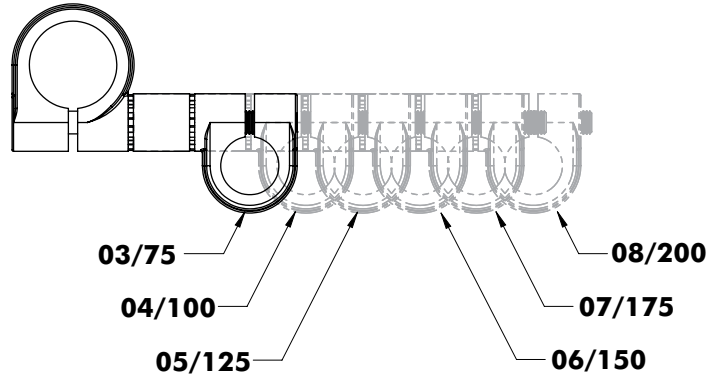
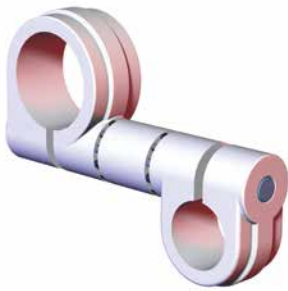

Model Number	(Ø)"D1"	(Ø)"D2"	"A"	"B"	"C"	Weight	FINISH
CPI-SA10-150-100-02	1.50"(in)	1.00"(in)	[2.66]	[2.01]	[3.89]	[0.53 lb]	SILVER
CPI-SA25-40-25-50	40mm	25mm	67.6	51.0	98.8	0.24 kg	BLUE
CPI-SA10-150-100-03	1.50"(in)	1.00"(in)	[3.53]	[3.07]	[4.95]	[0.64 lb]	SILVER
CPI-SA25-40-25-75	40mm	25mm	89.8	78.0	125.7	0.29 kg	BLUE
CPI-SA10-150-100-04	1.50"(in)	1.00"(in)	[4.41]	[4.05]	[5.93]	[0.73 lb]	SILVER
CPI-SA25-40-25-100	40mm	25mm	112.0	102.8	150.6	0.33 kg	BLUE
CPI-SA10-150-100-05	1.50"(in)	1.00"(in)	[5.33]	[5.04]	[6.92]	[0.83 lb]	SILVER
CPI-SA25-40-25-125	40mm	25mm	135.4	127.9	175.8	0.38 kg	BLUE
CPI-SA10-150-100-06	1.50"(in)	1.00"(in)	[6.28]	[6.03]	[7.91]	[0.93 lb]	SILVER
CPI-SA25-40-25-150	40mm	25mm	159.4	153.1	200.9	0.42 kg	BLUE
CPI-SA10-150-100-07	1.50"(in)	1.00"(in)	[7.22]	[7.01]	[8.89]	[1.04 lb]	SILVER
CPI-SA25-40-25-175	40mm	25mm	183.4	178.0	225.8	0.47 kg	BLUE
CPI-SA10-150-100-08	1.50"(in)	1.00"(in)	[8.19]	[8.00]	[9.88]	[1.13 lb]	SILVER
CPI-SA25-40-25-200	40mm	25mm	207.9	203.1	251.0	0.51 kg	BLUE

TRANSITION SWIVEL ARMS

Round Tooling | Dimensions | Technical Specifications

EDxx Double-Bolt Ø40mm/1.50" to Ø25mm/1.00"

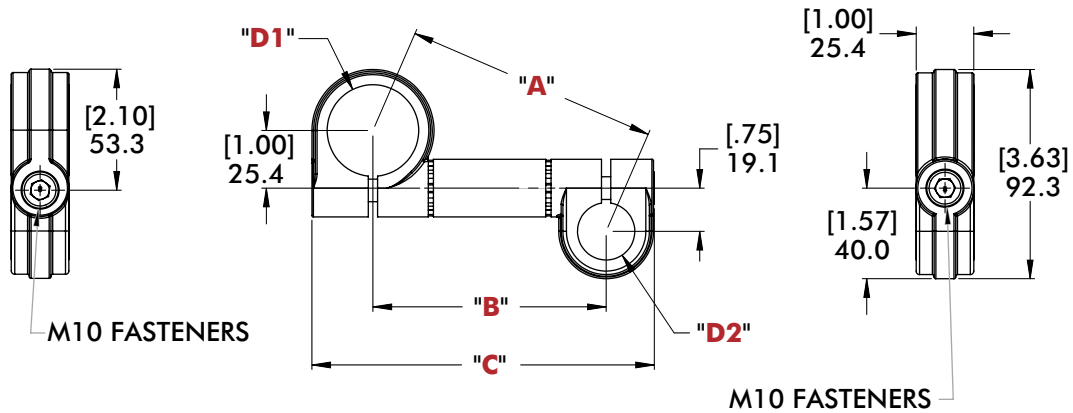

Model Number	(Ø)"D1"	(Ø)"D2"	"A"	"B"	"C"	Weight	FINISH
CPI-ED10-150-100-04	1.50"(in)	1.00"(in)	[4.46] 113.2	[4.10] 104.1	[5.98] 151.9	[0.71 lb] 0.32 kg	SILVER
CPI-ED25-40-25-100	40mm	25mm	[4.41] 112.8	[4.05] 102.8	[5.93] 150.6		BLUE
CPI-ED10-150-100-05	1.50"(in)	1.00"(in)	[5.39] 136.9	[5.10] 129.5	[6.98] 177.3	[0.78 lb] 0.36 kg	SILVER
CPI-ED10-150-100-06	1.50"(in)	1.00"(in)	[6.34] 161.1	[6.10] 154.9	[7.98] 202.7	[0.85 lb] 0.39 kg	SILVER
CPI-ED25-40-25-150	40mm	25mm	[6.28] 159.4	[6.03] 153.1	[7.91] 200.9		BLUE
CPI-ED10-150-100-07	1.50"(in)	1.00"(in)	[7.31] 185.7	[7.10] 180.3	[8.98] 228.1	[0.92 lb] 0.42 kg	SILVER
CPI-ED10-150-100-08	1.50"(in)	1.00"(in)	[8.28] 210.4	[8.10] 205.7	[9.98] 253.5	[0.99 lb] 0.45 kg	SILVER
CPI-ED25-40-25-200	40mm	25mm	[8.19] 207.9	[8.00] 203.1	[9.88] 251.0		BLUE
CPI-ED10-150-100-09	1.50"(in)	1.00"(in)	[9.26] 235.3	[9.10] 231.1	[10.98] 278.9	[1.06 lb] 0.48 kg	SILVER
CPI-ED10-150-100-10	1.50"(in)	1.00"(in)	[10.25] 260.3	[10.10] 256.5	[11.98] 304.3	[1.13 lb] 0.51 kg	SILVER
CPI-ED25-40-25-250	40mm	25mm	[10.12] 257.03	[9.97] 253.2	[11.85] 301.0		BLUE
CPI-ED10-150-100-11	1.50"(in)	1.00"(in)	[11.23] 285.3	[11.10] 281.9	[12.98] 329.7	[1.20 lb] 0.54 kg	SILVER
CPI-ED10-150-100-12	1.50"(in)	1.00"(in)	[12.22] 310.5	[12.10] 307.3	[13.98] 355.1	[1.27 lb] 0.57 kg	SILVER
CPI-ED25-40-25-300	40mm	25mm	[12.06] 306.4	[11.94] 303.2	[13.82] 351.03		BLUE
CPI-ED10-150-100-13	1.50"(in)	1.00"(in)	[13.21] 335.6	[13.10] 332.7	[14.98] 380.5	[1.34 lb] 0.61 kg	SILVER
CPI-ED10-150-100-14	1.50"(in)	1.00"(in)	[14.21] 360.8	[14.10] 358.1	[15.98] 405.9	[1.41 lb] 0.64 kg	SILVER
CPI-ED25-40-25-350	40mm	25mm	[14.00] 355.8	[13.90] 353.0	[15.78] 400.8		BLUE
CPI-ED10-150-100-15	1.50"(in)	1.00"(in)	[15.20] 386.0	[15.10] 383.5	[16.98] 431.3	[1.47 lb] 0.67 kg	SILVER
CPI-ED10-150-100-16	1.50"(in)	1.00"(in)	[16.19] 411.3	[16.10] 408.9	[17.98] 456.7	[1.54 lb] 0.70 kg	SILVER
CPI-ED25-40-25-400	40mm	25mm	[15.96] 405.5	[15.87] 403.0	[17.75] 450.9		BLUE

TRANSITION SWIVEL ARMS

Round Tooling | Dimensions | Technical Specifications

SAxx Single-Bolt Ø40mm/1.50" to Ø40mm/1.50"

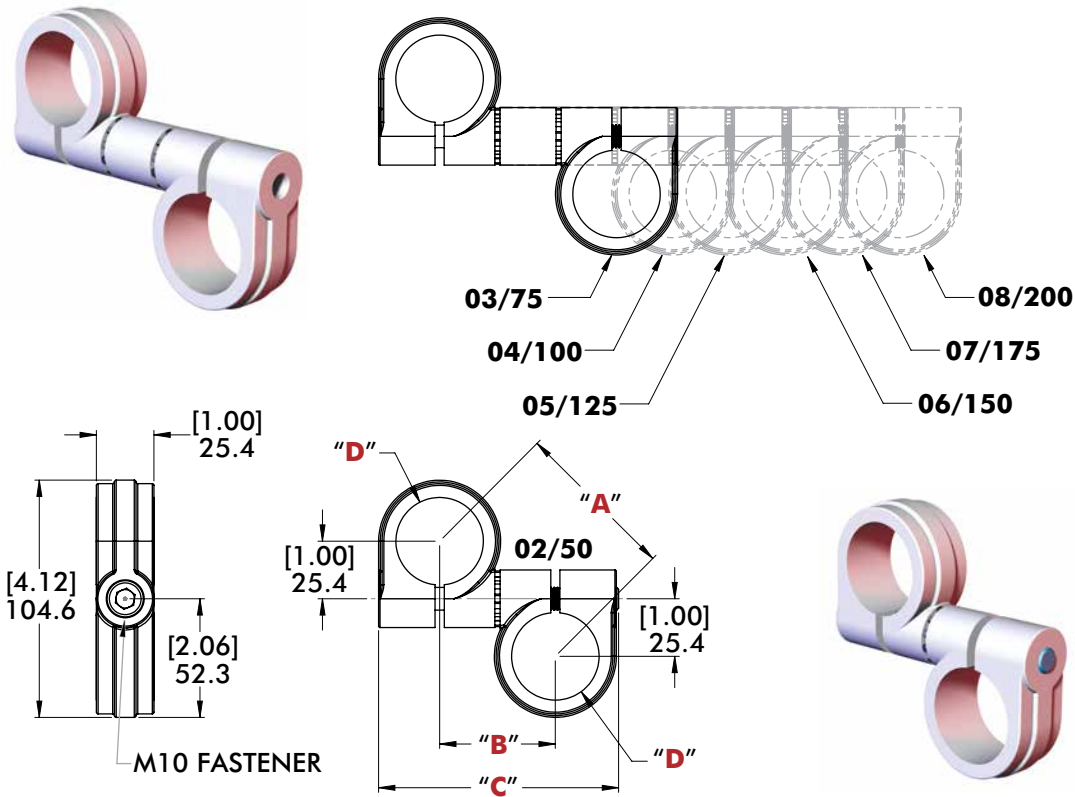

Model Number	(Ø)"D"	"A"	"B"	"C"	Weight	FINISH
CPI-SA10-150-150-02	1.50"(in)	[2.84]	[2.01]	[4.17]	[0.59 lb]	SILVER
CPI-SA25-40-40-50	40mm	72.0	51.1	105.9	0.27 kg	BLUE
CPI-SA10-150-150-03	1.50"(in)	[3.67]	[3.07]	[5.19]	[0.69 lb]	SILVER
CPI-SA25-40-40-75	40mm	93.2	78.1	131.9	0.31 kg	BLUE
CPI-SA10-150-150-04	1.50"(in)	[4.52]	[4.05]	[6.17]	[0.79 lb]	SILVER
CPI-SA25-40-40-100	40mm	114.7	102.9	156.7	0.36 kg	BLUE
CPI-SA10-150-150-05	1.50"(in)	[5.42]	[5.04]	[7.16]	[0.88 lb]	SILVER
CPI-SA25-40-40-125	40mm	137.7	128.0	181.9	0.40 kg	BLUE
CPI-SA10-150-150-06	1.50"(in)	[6.35]	[6.03]	[8.15]	[0.97 lb]	SILVER
CPI-SA25-40-40-150	40mm	161.4	153.2	207.0	0.44 kg	BLUE
CPI-SA10-150-150-07	1.50"(in)	[7.29]	[7.01]	[9.13]	[1.09 lb]	SILVER
CPI-SA25-40-40-175	40mm	185.2	178.1	231.9	0.49 kg	BLUE
CPI-SA10-150-150-08	1.50"(in)	[8.25]	[8.00]	[10.12]	[0.54 lb]	SILVER
CPI-SA25-40-40-200	40mm	209.5	203.2	257.0	1.18 kg	BLUE

TRANSITION SWIVEL ARMS

Round Tooling | Dimensions | Technical Specifications

EDxx Double-Bolt Ø40mm/1.50" to Ø40mm/1.50"

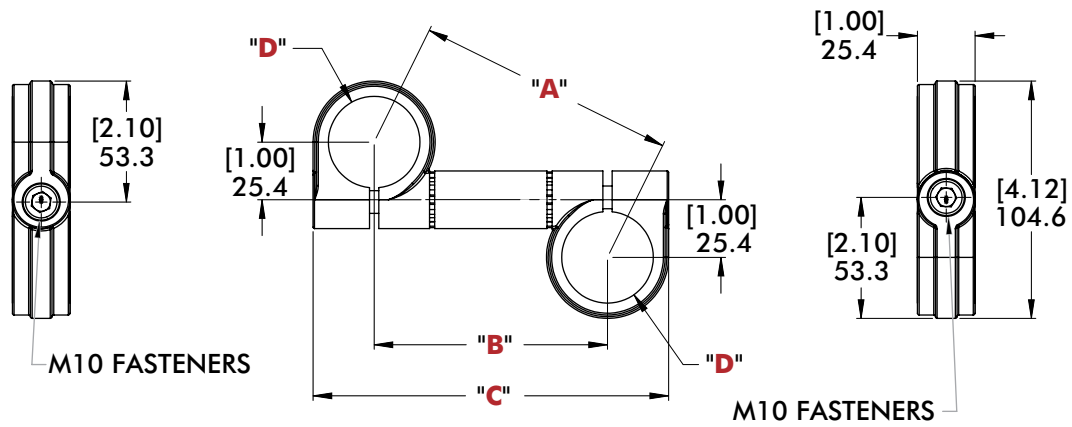

Model Number	(Ø)"D"	"A"	"B"	"C"	Weight	FINISH
CPI-ED10-150-150-04	1.50"(in)	[4.56] 115.9	[4.10] 104.1	[6.22] 158.0	[0.76 lb] 0.34 kg	SILVER
CPI-ED25-40-40-100	40mm	[4.52] 114.7	[4.05] 102.9	[6.17] 156.7		BLUE
CPI-ED10-150-150-06	1.50"(in)	[6.42] 163.1	[6.10] 154.9	[8.22] 208.8	[0.90 lb] 0.41 kg	SILVER
CPI-ED25-40-40-150	40mm	[6.35] 161.4	[6.03] 153.2	[8.15] 207.0		BLUE
CPI-ED10-150-150-08	1.50"(in)	[8.34] 211.9	[8.10] 205.7	[10.22] 259.6	[1.03 lb] 0.47 kg	SILVER
CPI-ED25-40-40-200	40mm	[8.25] 209.5	[8.00] 203.2	[10.12] 257.0		BLUE
CPI-ED10-150-150-10	1.50"(in)	[10.30] 261.5	[10.10] 256.4	[12.22] 310.4	[1.17 lb] 0.53 kg	SILVER
CPI-ED25-40-40-250	40mm	[10.17] 258.3	[9.97] 253.2	[12.09] 307.1		BLUE
CPI-ED10-150-150-12	1.50"(in)	[12.27] 311.5	[12.10] 307.3	[14.22] 361.2	[1.31 lb] 0.59 kg	SILVER
CPI-ED25-40-40-300	40mm	[12.11] 307.5	[11.94] 303.3	[14.06] 357.1		BLUE
CPI-ED10-150-150-14	1.50"(in)	[14.24] 361.7	[14.10] 358.1	[16.22] 411.98	[1.45 lb] 0.66 kg	SILVER
CPI-ED25-40-40-350	40mm	[14.03] 356.7	[13.90] 353.1	[16.02] 406.9		BLUE
CPI-ED10-150-150-16	1.50"(in)	[16.22] 412.1	[16.10] 408.9	[18.22] 462.7	[1.59 lb] 0.72 kg	SILVER
CPI-ED25-40-40-400	40mm	[16.00] 406.3	[15.87] 403.1	[18.00] 457.0		BLUE