

500 SERIES

Weldable Vertical Hold Down Clamps | Product Overview

Features:

- Hardened pivot pins and bushings
- Weldable clamping bar
- LSC version with locking spring clip for securing the handle in the open position
- Modular design allows you to set up the clamp to meet application requirements

Applications:

- Welding
- Assembly
- Heavy duty, production clamping applications

Also Available:

See page MC-VHD-44 for accessories

501-B ⓘ
Swivel Base



501-LB ⓘ
Long Base



503-MB
Swivel Base



503-MLB
Long Base



503-MBLSC ⓘ
Swivel Base with Locking Spring Clip



503-MLBLSC ⓘ
Long Base with Locking Spring Clip



505-MB
Swivel Base



505-MLB
Long Base



505-MBLSC ⓘ
Swivel Base with Locking Spring Clip



505-MLBLSC ⓘ
Long Base with Locking Spring Clip



506-MB
Swivel Base



506-MLB ⓘ
Long Base



506-MBLSC ⓘ
Swivel Base with Locking Spring Clip



506-MLBLSC ⓘ
Long Base with Locking Spring Clip



Model 505-MLB in a robotic welding fixture

ⓘ This item is available upon request

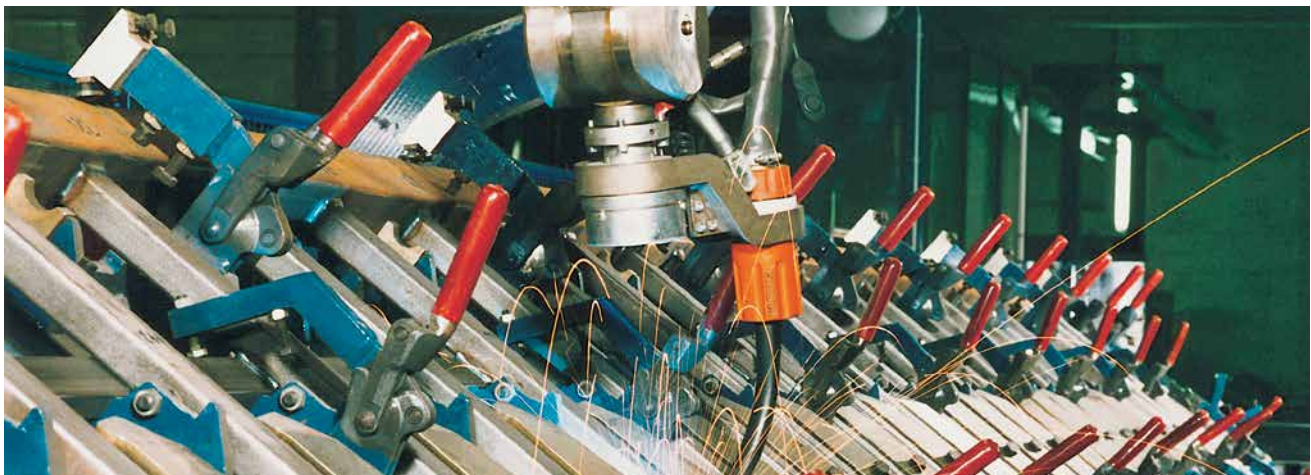

Vertical Hold Down Clamps | Technical Information

Model	Max. Holding Capacity	Clamp Bar Opening (+10°)	Weight
501-B ⓘ	2000 N [450 lbf]	200°	0,18kg [0.40lbs]
501-LB ⓘ			0,20kg [0.44lbs]
503-MB	7000 N [1575 lbf]		0,70kg [1.54lbs]
503-MLB			0,80kg [1.76lbs]
503-MBLSC ⓘ			
503-MLBLSC ⓘ			
505-MB	11000 N [2475 lbf]		1,40kg [3.09lbs]
505-MLB			1,50kg [3.31lbs]
505-MBLSC ⓘ			
505-MLBLSC ⓘ			
506-MB	22500 N [5060 lbf]		2,60kg [5.73lbs]
506-MLB ⓘ			2,80kg [6.17lbs]
506-MBLSC ⓘ			
506-MLBLSC ⓘ		3,00kg [6.61lbs]	

Note:

The clamping bars are made from forged alloy steel and must be heated to 200°C(400°F) prior to welding. We recommend welding the handles, clamp arms, and mounting bases when disassembled. Welding of non pre-heated parts may only be done with the addition of welding fillers.

ⓘ This item is available upon request

Clamping Position

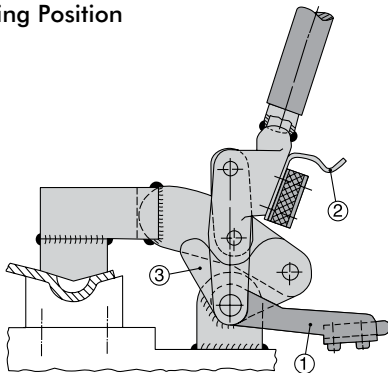

Patented spring latch hold-open device

1. Mount the clamp and place it in the closed position
2. Position the bracket in the leaf spring

Open Position

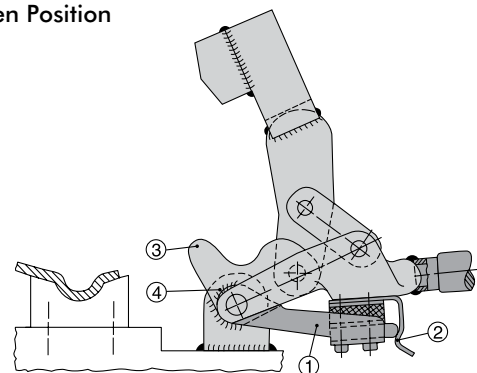

3. Swivel the clamp into the open position
4. In this position, weld the bracket with the bar guide feature at point

500 SERIES

Weldable Vertical Hold Down Clamps | Dimensions | -B/-LB/-MB/-MLB/-MBLSC/-MLBLSC

Swivel Base

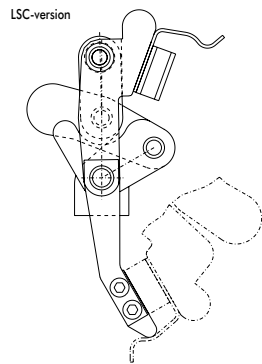
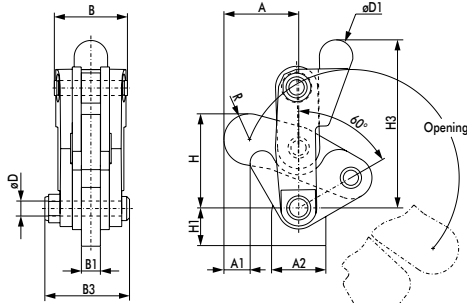

503-MB
Swivel
Base



Long Base

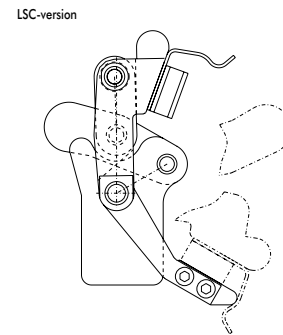
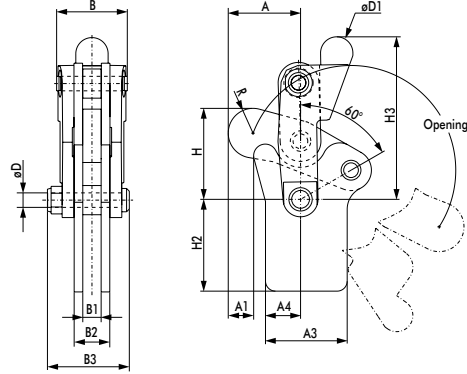

503-MLB
Long Base

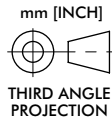

Swivel Base Dimensions

Model	A	A1	A2	B	B1	B3	ØD	ØD1	H	H1	H3	R
501-B ⓘ	[1.13] 28,6	[0.56] 14,3	[0.75] 19,1	[0.79] 20,0	[0.25] 6,4	[1.09] 27,8	[0.19] 4,8	[0.50] 12,7	[1.12] 28,5	[0.79]	[2.20] 56	[0.37] 9,5
503-MB	[1.54]	[0.50]	[1.12]	[1.52]	[0.39]	[1.82]	[0.31]	[0.69]	[1.96]	20	[3.51]	[0.53]
503-MBLSC ⓘ	39,2	12,8	28,5	38,5	10	46,2	8	17,5	49,8		89,1	13,5
505-MB	[2.22]	[1.02]	[1.38]	[1.89]	[0.48]	[2.31]	[0.37]	[0.87]	[2.79]	[1.10]	[4.33]	[0.72]
505-MBLSC ⓘ	56,5	25,9	35	48	12,3	58,6	9,5	22,2	70,8	28	110,1	18,3
506-MB	[2.82]	[1.27]	[1.97]	[1.91]	[0.63]	[2.72]	[0.47]	[0.94]	[3.45]	[1.29]	[5.30]	[0.84]
506-MBLSC ⓘ	71,7	32,3	50	48,4	16	69	12	24	87,7	32,8	134,6	21,4

Long Base Dimensions

Model	A	A1	A3	A4	B	B1	B2	B3	ØD	ØD1	H	H2	H3	R
501-LB ⓘ	[1.13] 28,6	[0.50]	[1.13] 28,6	[0.56] 14,3	[0.79] 20	[0.25] 6,4	[0.51] 13	[1.09] 27,8	[0.19] 4,8	[0.50] 12,7	[1.12] 28,5	[1.32] 33,5	[2.21] 56,1	[0.37] 9,5
503-MLB	[1.54]	12,8	[1.75]	[0.75]	[1.52]	[0.39]	[0.79]	[1.82]	[0.31]	[0.69]	[1.96]	[1.97]	[3.51]	[0.53]
503-MLBLSC ⓘ	39,2		44,5	19	38,5	10	20	46,2	8	17,5	49,8	50	89,1	13,5
505-MLB	[2.22]	[1.02]	[2.09]	[1.08]	[1.89]	[0.48]	[0.88]	[2.31]	[0.37]	[0.87]	[2.79]	[2.50]	[4.33]	[0.72]
505-MLBLSC ⓘ	56,5	25,9	53	27,5	48	12,3	22,3	58,6	9,5	22,2	70,8	63,5	110,1	18,3
506-MLB	[2.82]	[1.27]	[2.58]	[1.45]	[1.91]	[0.63]	[1.10]	[2.72]	[0.47]	[0.94]	[3.45]	[3.00]	[5.30]	[0.84]
506-MLBLSC ⓘ	71,7	32,3	65,5	36,9	48,4	16	28	69	12	24	87,7	76,2	134,6	21,4 [8.43] 214

Features:

- Used with 500 Series Vertical Clamps
- Allows you to customize the clamp to suit application requirements

Applications:

- Welding
- Assembly
- Heavy duty, production clamping applications

Also Available:

See page MC-VHD-41 for clamp linkage

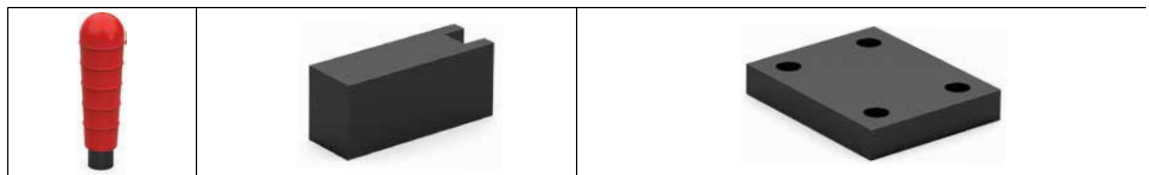
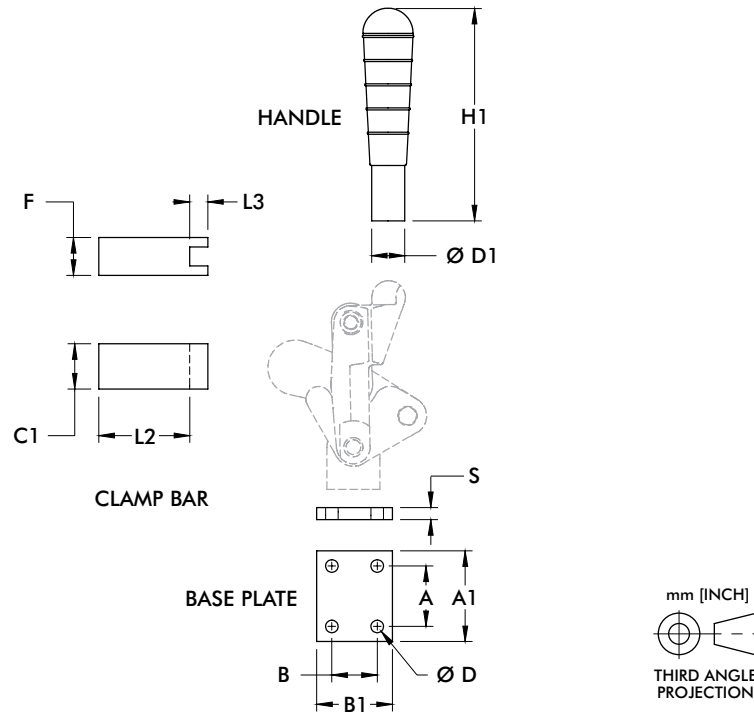

Use with	Part No.	Handle						Clamping Bar				Base Plate			
		ØD1	H1	C1	F	L2	L3	A	A1	B	B1	ØD	S		
501	501503 ⓘ	6x10	61	-	-	-	-	-	-	-	-	-	-		
	501501 ⓘ	-	-	15	15	40	10	-	-	-	-	-	-		
	503502	-	-	-	-	-	-	25	40	35	50	6.3	8		
503	503503-L	Ø18	129.5	-	-	-	-	-	-	-	-	-	-		
	503501	-	-	25	20	50	8	-	-	-	-	-	-		
	503502	-	-	-	-	-	-	25	40	35	50	6.3	8		
505	505503-L	Ø22	159	-	-	-	-	-	-	-	-	-	-		
	505501	-	-	30	25	60	12	-	-	-	-	-	-		
	505502	-	-	-	-	-	-	40	60	30	50	8.1	8		
506	506503-L	Ø28	188	-	-	-	-	-	-	-	-	-	-		
	506501	-	-	35	30	75	15	-	-	-	-	-	-		
	506502	-	-	-	-	-	-	50	70	45	65	8.1	8		

ⓘ This item is available upon request Note: Dimensions shown in millimeters.