

7-101, 7-58, 7-59, 7-60 SERIES

Heavy Duty Cam Action Series | Product Overview

Features:

- Cam action accommodates variable workpiece thickness
- Heavy duty construction
- Solid clamp arms may be modified to suit application requirements

Applications:

- Light machining
- Welding
- Assembly

7-101



7-58
7-59
7-60



Technical Information

Model	Max. Holding Capacity	Clamp Bar Opening (+10°)	Weight
7-101	2110 N [475 lbf]	80°	0,45 kg [1.0 lbs]
7-58	2670 N [600 lbf]	95°	0,91 kg [2.0 lbs]
7-59	4450 N [1000 lbf]	95°	1,36 kg [3.0 lbs]
7-60	7120 N [1600 lbf]	80°	2,27 kg [5.0 lbs]

Holding Forces | Dimensions

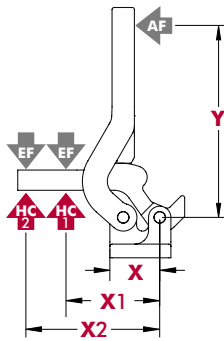

Model	X	X1	X2	Y	±HC1	±HC2	±EF(X1):AF	±EF(X2):AF
7-58	[1.38] 35.1	[2.36] 60	[3.54] 90	[5.31] 135	[600 lbf] 2670 N	[400 lbf] 1780 N	5:1	3:1
7-59	[1.69] 42.8	[3.46] 88	[4.72] 120	[6.69] 170	[1000 lbf] 4450 N	[725 lbf] 3225 N	4:1	3:1
7-60	[2.00] 50.8	[4.53] 115	[5.90] 150	[7.48] 190	[1600 lbf] 7120 N	[1225 lbf] 5450 N	4:1	3:1
7-101	[1.00] 25.4	[1.97] 50	[3.74] 95	[3.46] 88	[475 lbf] 2110 N	[250 lbf] 1110 N	1.50:1	1.25:1

Dimensions shown "mm [inch]" ± HC = Holding Capacity, EF = Exerting Force, AF = Applied Force
See page MC-TEC-4 for additional information.

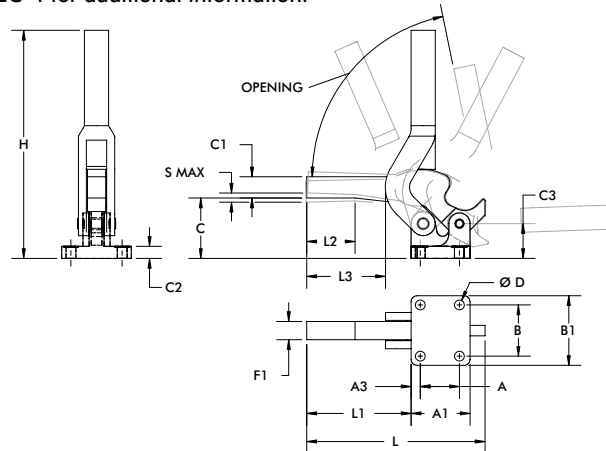

mm [INCH]



Model	A	A1	A3	B	B1	C	C1	C2	C3	D	F1	H	L	L1	L2	S max.
7-101	[0.75] 19,1	[1.25] 31,8	[0.25] 6,1	[1.25] 31,8	[1.75] 44,5	[1.44] 36,6	[0.50] 12,7	[0.31] 7,9	[1.00] 25,4	[0.22] 5,6	[0.50] 12,7	[5.00] 127	[4.62] 117,3	[3.12] 79,1	-	[0.13] 3,3
7-58	[1.00] 25,4	[1.69] 42,9	[0.34] 8,6	[1.62] 41,2	[2.25] 57,2	[1.87] 47,5	[0.56] 14,2	[0.38] 9,7	[1.12] 28,5	[0.28] 7,1	[0.50] 12,7	[6.93] 176	[4.62] 117,35	[2.55] 64,8	-	[0.13] 3,3
7-59	[1.38] 35,1	[2.06] 52,3	[0.39] 9,9	[1.88] 47,8	[2.50] 63,5	[2.19] 55,6	[0.63] 16	[0.44] 11,2	[1.25] 31,8	[0.34] 8,6	[0.63] 16	[8.50] 215,9	[6.00] 152,4	[3.45] 87,6	[1.24] 31,5	[0.19] 4,8
7-60	[1.62] 41,2	[2.44] 62	[0.44] 11,2	[2.12] 53,9	[2.88] 73,2	[2.50] 63,5	[0.88] 22,4	[0.50] 12,7	[1.44] 36,6	[0.41] 10,4	[0.75] 19,1	[9.44] 239,8	[7.38] 187,5	[4.32] 109,7	[1.97] 50	[0.25] 6,4