

# MANIFOLDS

Vacuum Products | Dimensions | Technical Specifications

## MBC/MLK Boom Mounted Single 4-Port - 30° Angled Input Port

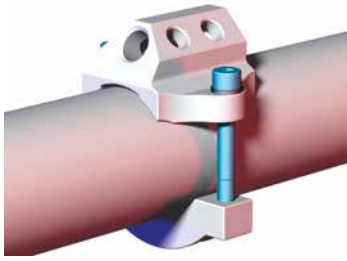

**Features:**

- 30° Angled input port.
- Provides a 4-port air distribution system mount on the boom.

**Specifications:**

**Material:** Aluminum

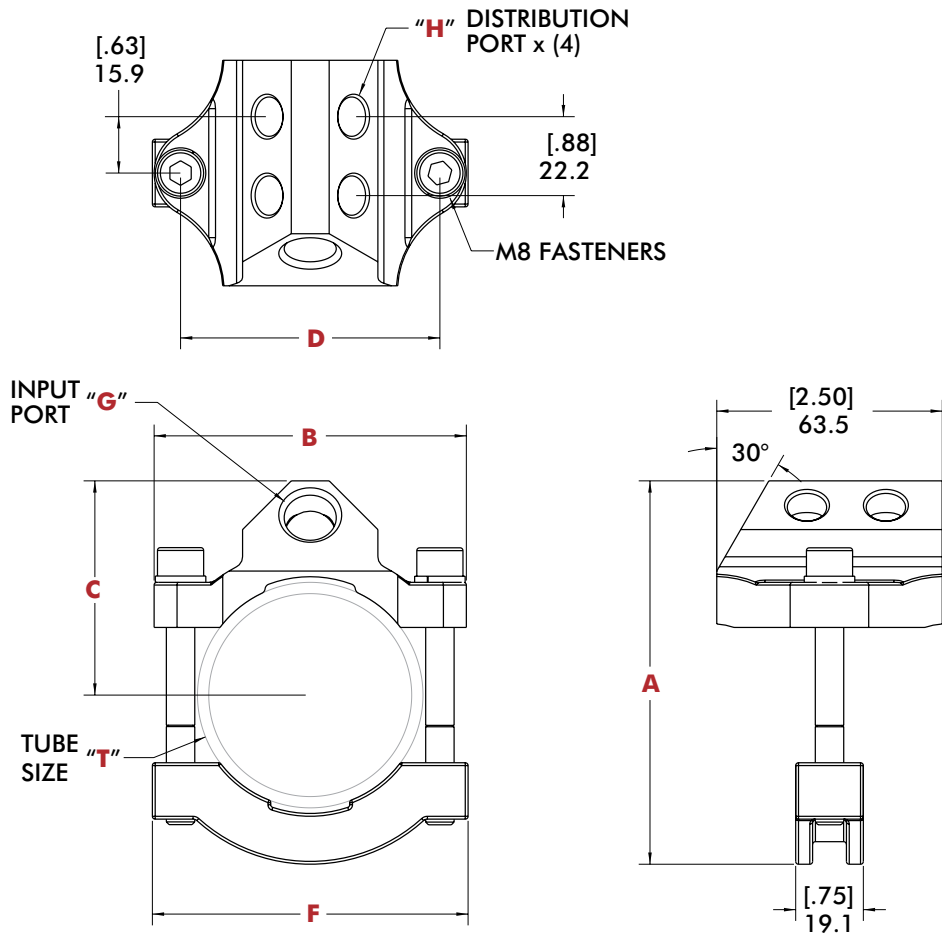

**MBC/MLK Dimensions**

Model	A	B	C	D	F	G	H	T	Weight
CPI-MLK-60-G44-30	108.0	87.9	60.3	73	88.9	3/8 G	1/4 G	Ø60MM	340g
[CPI-MBC-250-4-4-30]	[4.25]	[3.46]	[2.38]	[2.88]	[3.50]	[3/8 NPT]	[1/4 NPT]	[Ø2.50"]	[12 oz]

# MANIFOLDS

Vacuum Products | Dimensions | Technical Specifications

## MBC/MLK Boom Mounted Single 4-Port

### Specifications:

Material: Aluminum

### Features:

- Provides a 4-port air distribution system mount on the boom.
- Available in two sizes to allow clamping to Ø40mm [Ø1.50"] and Ø60mm [Ø2.50"] materials.

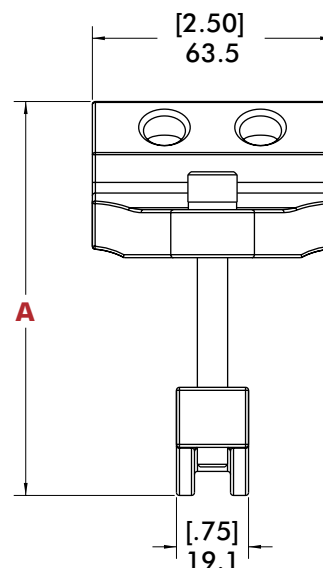
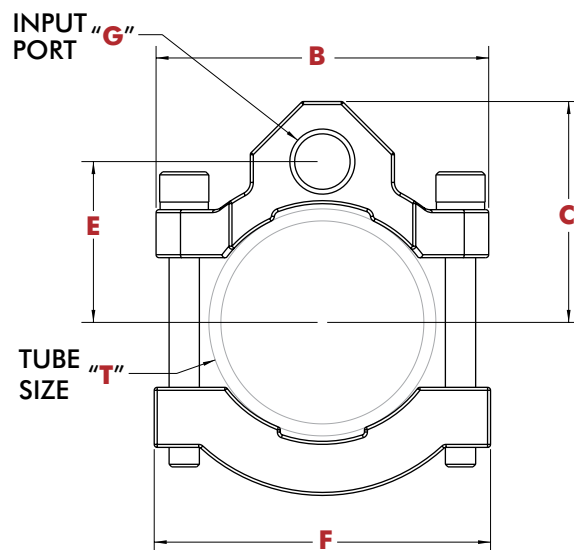
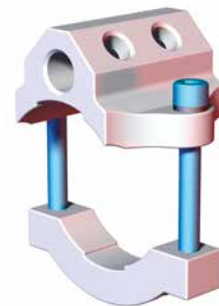
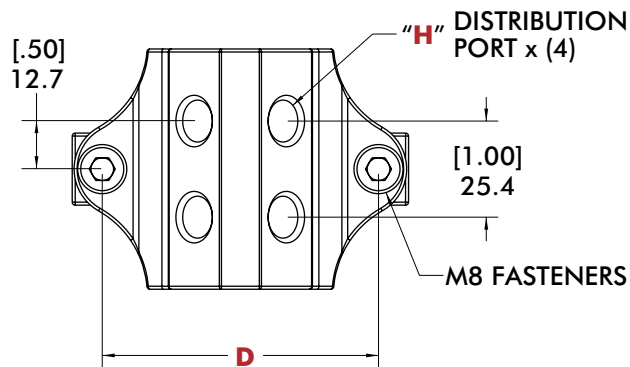
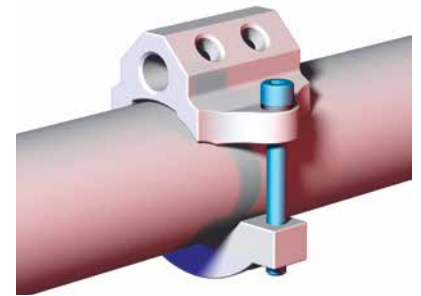

### MBC/MLK Dimensions

Model	A	B	C	D	E	F	G	H	T	Weight
CPI-MLK-40-G44	88.9	64.3	52.5	48.5	36.7	64.3	12.9	114.5	Ø40MM	283g
[CPI-MBC-150-4-4]	[3.50]	[2.53]	[2.07]	[1.91]	[1.44]	[2.53]	[.51]	[4.51]	[Ø1.50"]	[10 oz]
CPI-MLK-60-G44	104.1	87.9	58.4	73	42.5	88.9	39.7	118.4	Ø60MM	340g
[CPI-MBC-250-4-4]	[4.10]	[3.46]	[2.30]	[2.88]	[1.67]	[3.50]	[1.56]	[4.65]	[Ø2.50"]	[12 oz]

# MANIFOLDS

Vacuum Products | Dimensions | Technical Specifications

## MBC/MLK Boom Mounted Double 8-Port

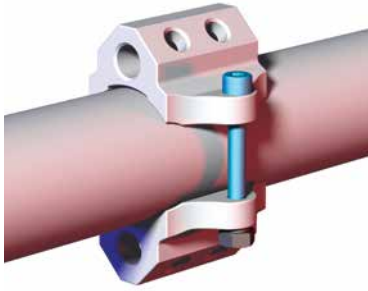

### Features:

- Provides an 8-port (4 ports on top and bottom) air distribution system mount on the boom.
- Available in two sizes to allow clamping to Ø40mm [Ø1.50"] and Ø60mm [Ø2.50"] materials.

### Specifications:

Material: Aluminum

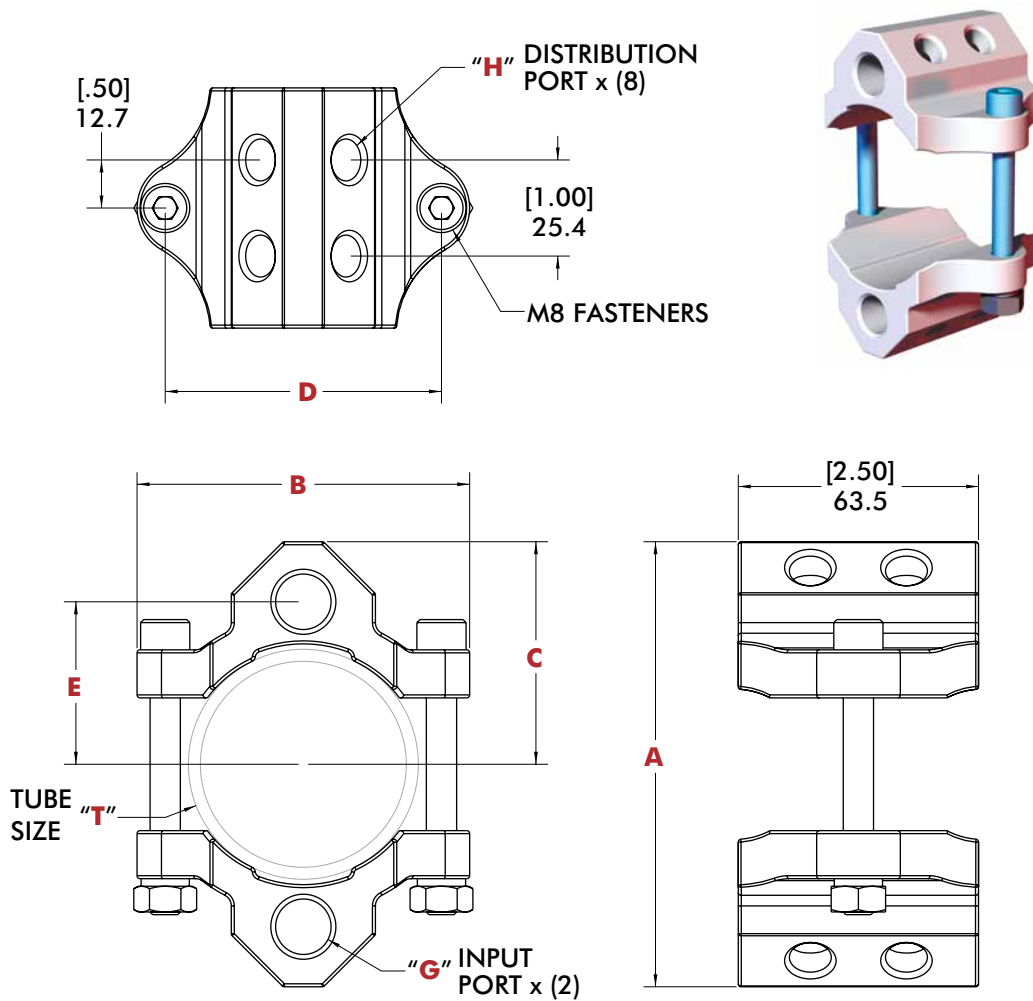

### MBC/MLK Dimensions

Model	A	B	C	D	E	G	H	T	Weight
CPI-MLK-40-G88 [CPI-MBC-150-8-8]	105.1 [4.14]	64.3 [2.53]	52.5 [2.07]	48.5 [1.91]	36.8 [1.45]	3/8 G [3/8 NPT]	1/4 G [1/4 NPT]	Ø40MM [Ø1.50"]	425g [16 oz]
CPI-MLK-60-G88 [CPI-MBC-250-8-8]	117.6 [4.63]	87.9 [3.46]	58.8 [2.32]	73.0 [2.88]	42.9 [1.69]	3/8 G [3/8 NPT]	1/4 G [1/4 NPT]	Ø60MM [Ø2.50"]	510g [18 oz]

# MANIFOLDS

Vacuum Products | Dimensions | Technical Specifications

## MBC Boom Mounted Single 6-Port

**Specifications:**

**Material:** Aluminum

**Features:**

- Provides a 6-port air distribution system mounted on the boom.
- Easy access.

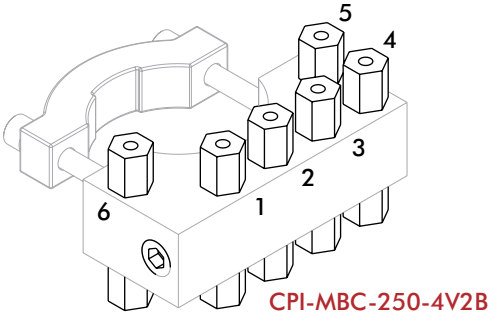
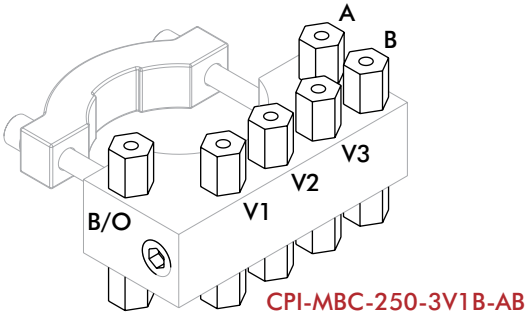
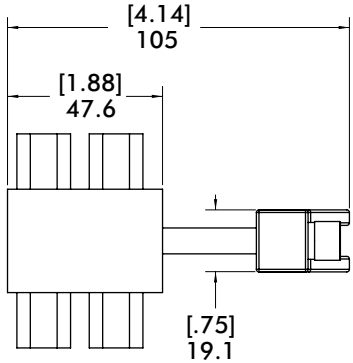
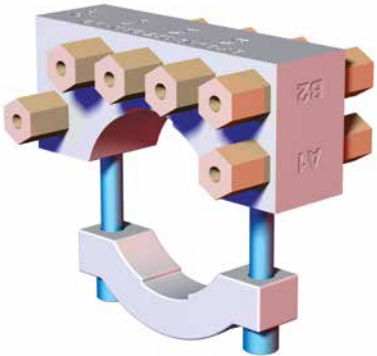
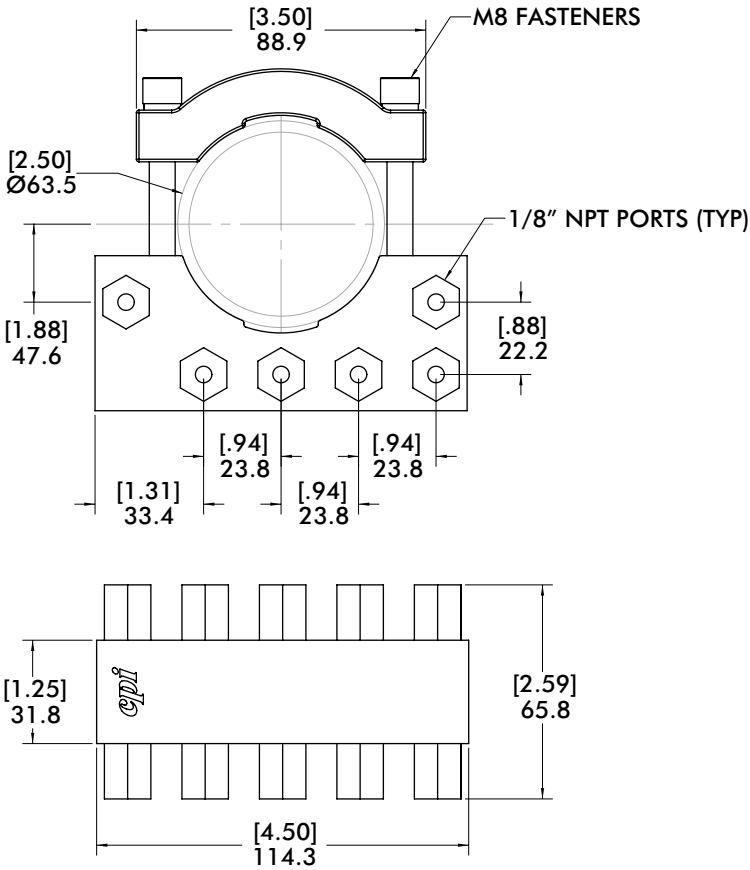
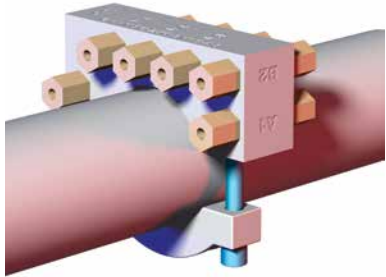

# MANIFOLDS

Vacuum Products | Dimensions | Technical Specifications

**GDA/MBB** Block Style for Remote Mounting

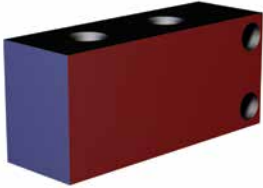

Material: Aluminum

Model	Weight
CPI-GDA-M24-37327	.23 kg [.56 lb]

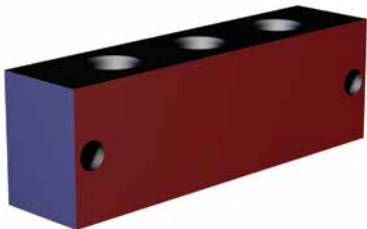
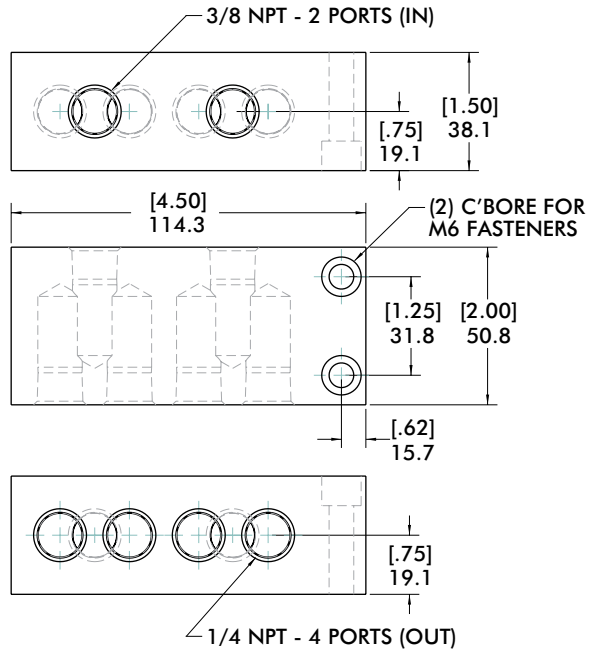

Material: Aluminum

Model	Weight
CPI-MMB-4V2B-LG	.23 kg [.56 lb]

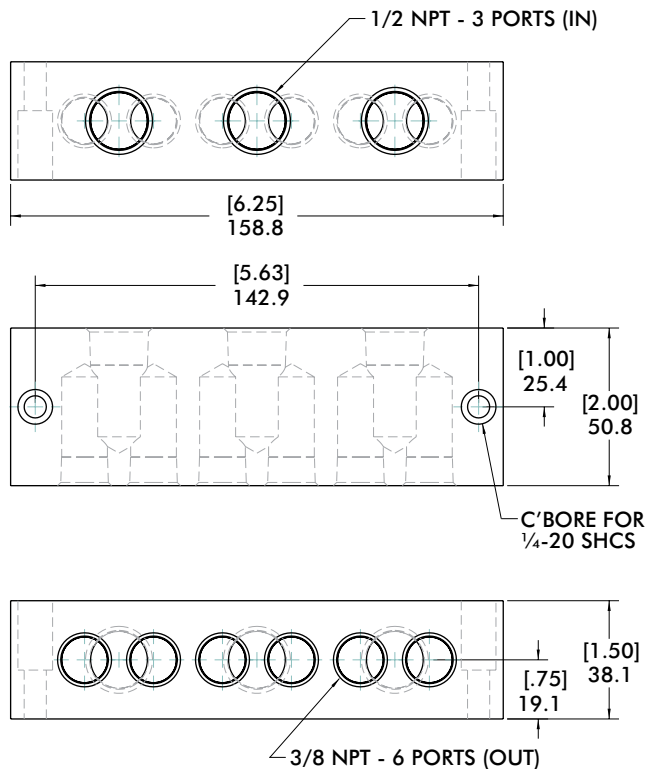

# MANIFOLDS

Vacuum Products | Dimensions | Technical Specifications

## MMB Block Style or Remote Mounting

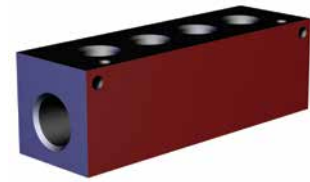
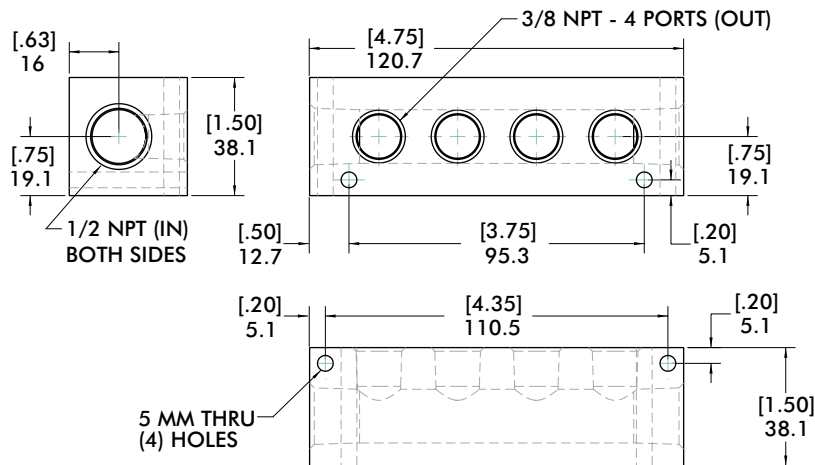

Material: Aluminum

Model	Weight
CPI-MMB-4P	.23 kg [.56 lb]

## MMB Block Style or Remote Mounting

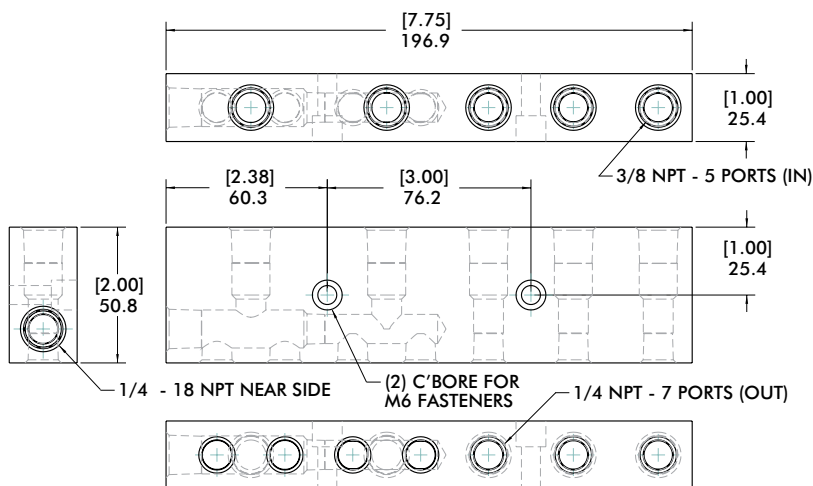

Material: Aluminum

Model	Weight
CPI-MMB-4VSP-AB	.23 kg [.56 lb]

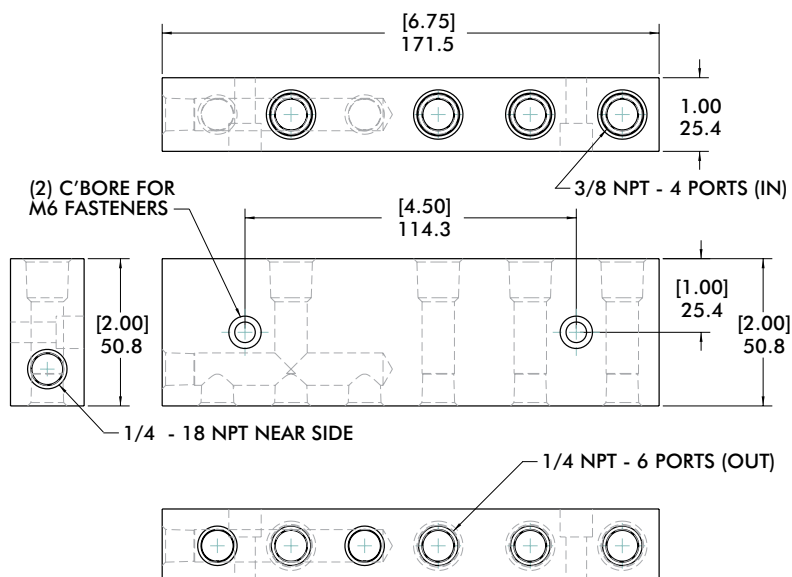

Material: Aluminum

Model	Weight
CPI-MMB-3V1B-AB	.23 kg [.56 lb]

# BODYBUILDER™ TOOLING EXAMPLES



## Table of Contents

	BodyBuilder™ Extruded Aluminum Octagonal Booms .....	5
	BodyBuilder™ Structure Mid Mount Assemblies .....	11
	BodyBuilder™ Structure End Mount Assemblies.....	28
	BodyBuilder™ Transition Brackets and Blocks.....	32
	BodyBuilder™ Low-Profile Transition Brackets .....	48
	BodyBuilder™ Accessory Brackets and Mounts .....	68
	BodyBuilder™ Gripper Mounts .....	72
	BodyBuilder™ Swivel Arm Mounts .....	75
	BodyBuilder™ Swivel Arm Accessories .....	79





**Mid Mount with GR84 Series Mini-Clamps**

**Mid Mount with GR1 Series Gripper**

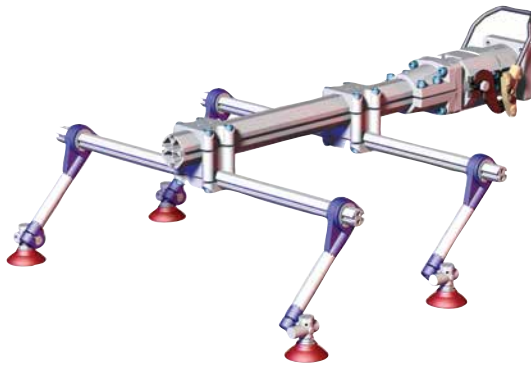
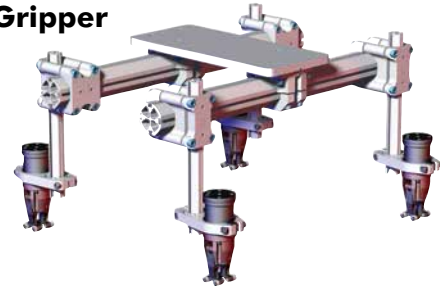

**End Mount with Venturi Cup Mounts and Vacuum Cups**



**End Mount with GR84 Series Mini Clamp**

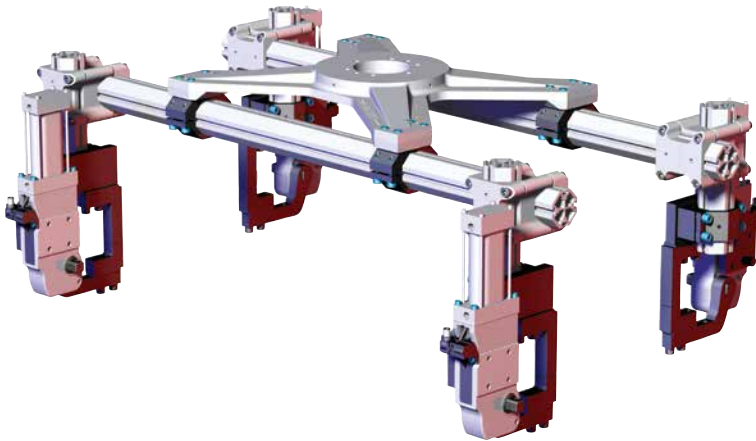

**Mid Mount with 82M50 Enclosed Power Clamps**

**Mid Mounted Part Nest with CPI-HTW Hold Table Weldment and Nest Pad guides**

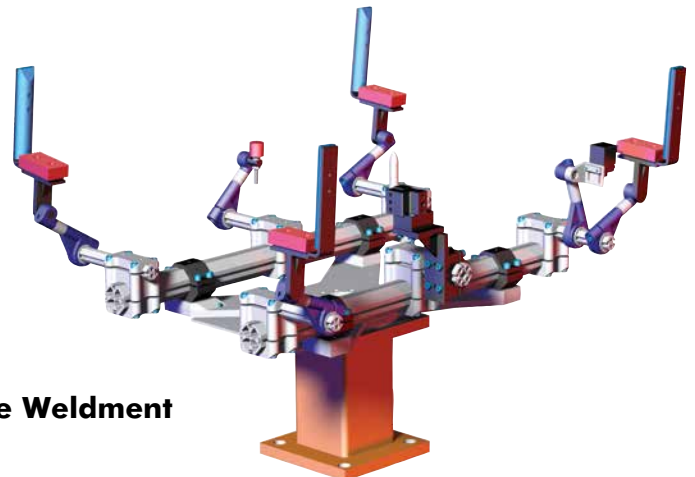



# BODYBUILDER™ END EFFECTOR SYSTEM



## Product Overview

BodyBuilder™ is designed to maximize productivity, both before and after installation. The flexibility of the system allows modifications to the end effector in minutes, greatly reducing start up time to launch.

The octagonal structure is available in four sizes: 30mm, 45mm, 60mm, and 90mm.

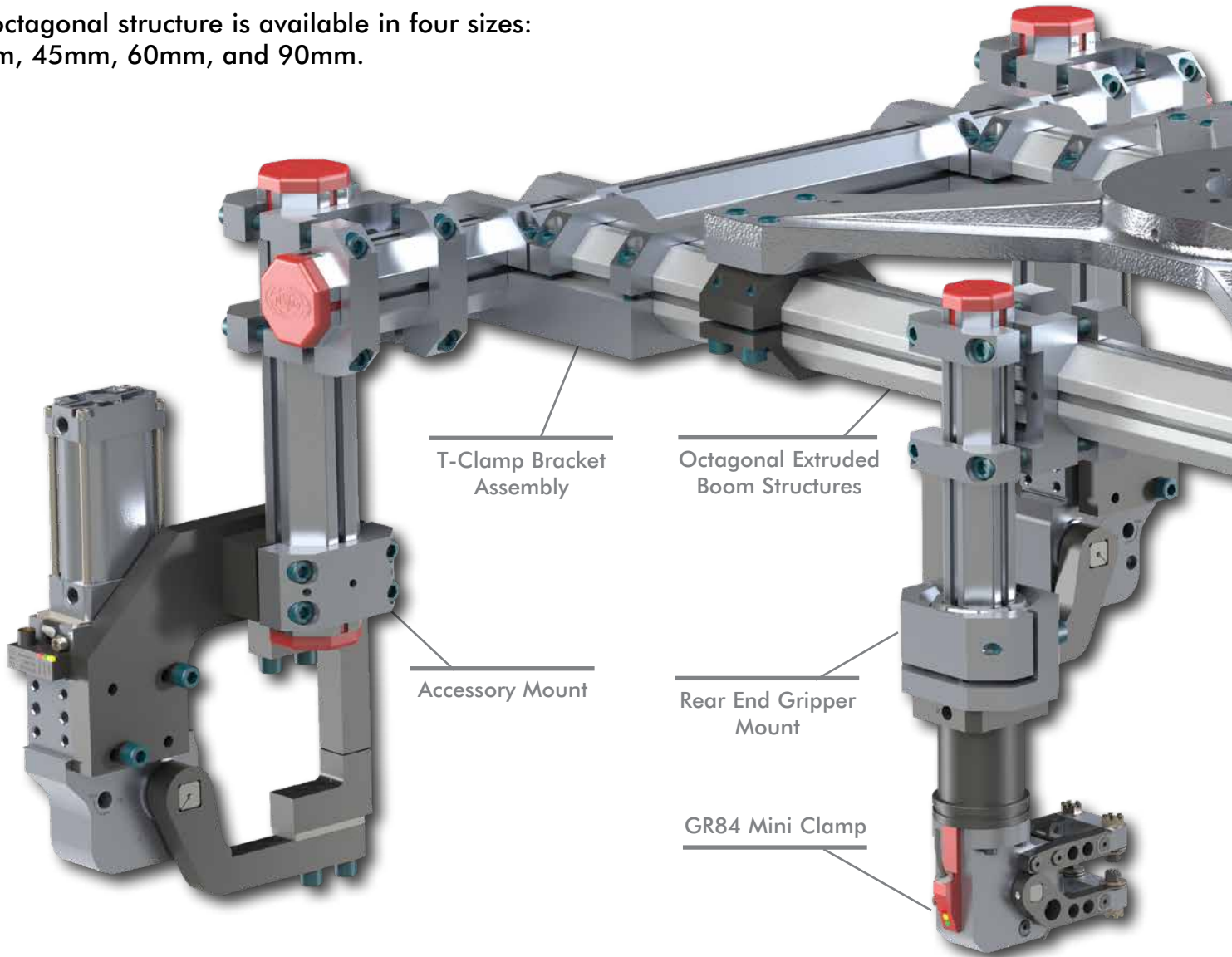

The patented BodyBuilder™ Alignment System allows the modular components to be replaced individually and easily returned to their original positions.

Alignment nut(s) are included with every Bodybuilder™ modular component, utilizing the patented alignment system.

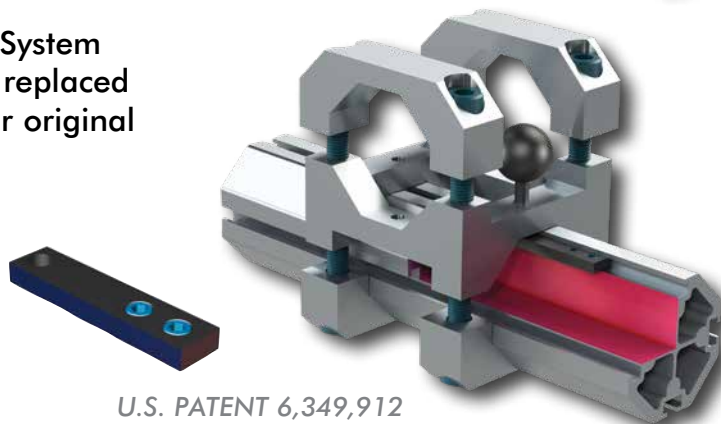

**Most commonly used in:**

Applications	Markets
Robot Welding	Industrial
Pick and Place	Automotive
Material Handling	Transportation
Lower Nest	Appliance

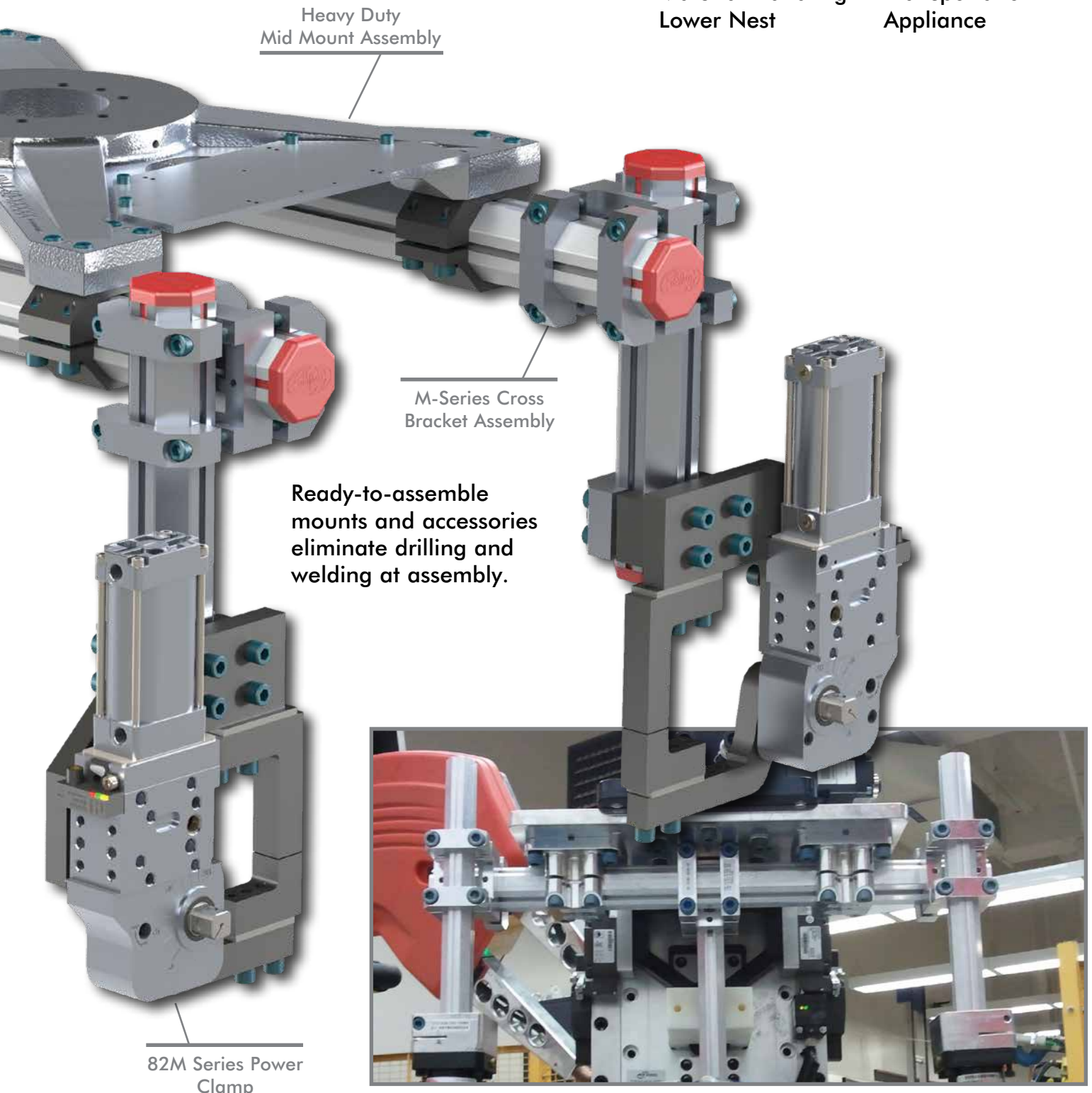

Heavy Duty  
Mid Mount Assembly

M-Series Cross  
Bracket Assembly

Ready-to-assemble  
mounts and accessories  
eliminate drilling and  
welding at assembly.

82M Series Power  
Clamp