



ComInTec®

FLOHR
INDUSTRIE-TECHNIK GMBH

PNEUMATIC CLUTCHES

Up to 30 KNm and 120 mm bore diameters

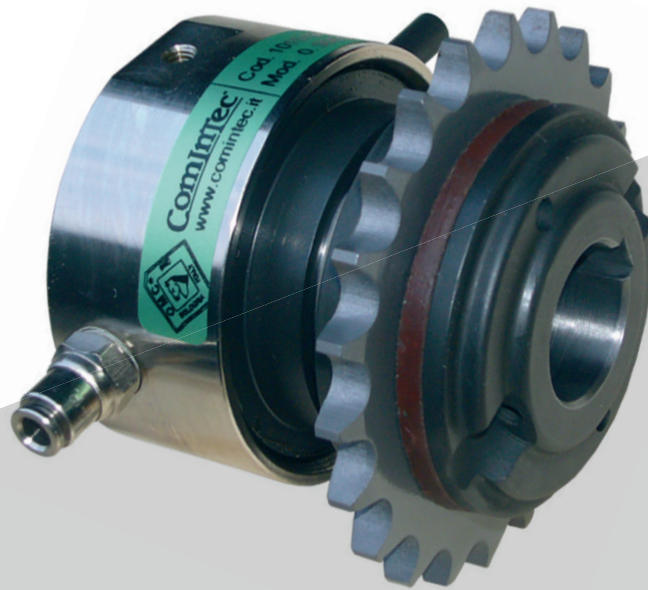

- Download catalogue
- Download instruction sheets

AP

AP - pneumatic clutches: introduction



- ⊙ Simple and precise calibration.
 - ⊙ Transmission engagement / disengagement and torque limiter functions (safety coupling).
 - ⊙ Reliability and repetitiveness of the calibration torque.
 - ⊙ Torque variation whilst in motion, by pressure regulation.
 - ⊙ Free rotation after the disengagement through a complete disconnection between the parts.
 - ⊙ Low residual torque on disconnected parts.
 - ⊙ Models available only with finished bore.
- ON REQUEST
- ⊙ Complete with transmission element machined and assembled (plate wheel, pulley, gear, ...).
 - ⊙ Can be supplied with various types of rigid/elastic couplings for in-line shafts transmission.
 - ⊙ Possibility of shaft connection with finished bore, locking assembly or other systems.
 - ⊙ Available in anti-corrosive version, with specific surface treatments.





A friction clutch or roller with torque adjustment even during operation. Ability to disengage the drive and driven by pneumatic or electrical impulse. Low residual torque after disengagement. Calibration adjustable by changing the pressure (pneumatic) air supply.

APPLICATION FIELD

- ⊙ Machines with variable torque requirements.
- ⊙ Test benches.
- ⊙ Coiler and uncoilers.
- ⊙ Cut format systems.

ADVANTAGES AND BENEFITS

- ⊙ Engage/disengage different product transmission lines.
- ⊙ Maintain tension of wire/film coils.
- ⊙ Regulate different torques depending on the change of the format.
- ⊙ Protect the motor gearbox against every form of overload.

	DSR/F/AP: Complete engagement-disengagement of the transmission, also for long periods	from 7 to 30 KNm 120 mm max bore	Page 67
	DSR/F/AP + GEC: compact coaxial connection for simple maintenance without being forced to remove the coupling	from 7 to 30 KNm 180 mm max bore	Page 68
	DSF/TF/AP: friction motion transmission as tensioner.	from 3 to 875 Nm 65 mm max bore	Page 69
	DSF/TF/AP/TAC: simple and economic coaxial shaft connection.	from 3 to 875 Nm 80 mm max bore	Page 70

ASSEMBLY EXAMPLES

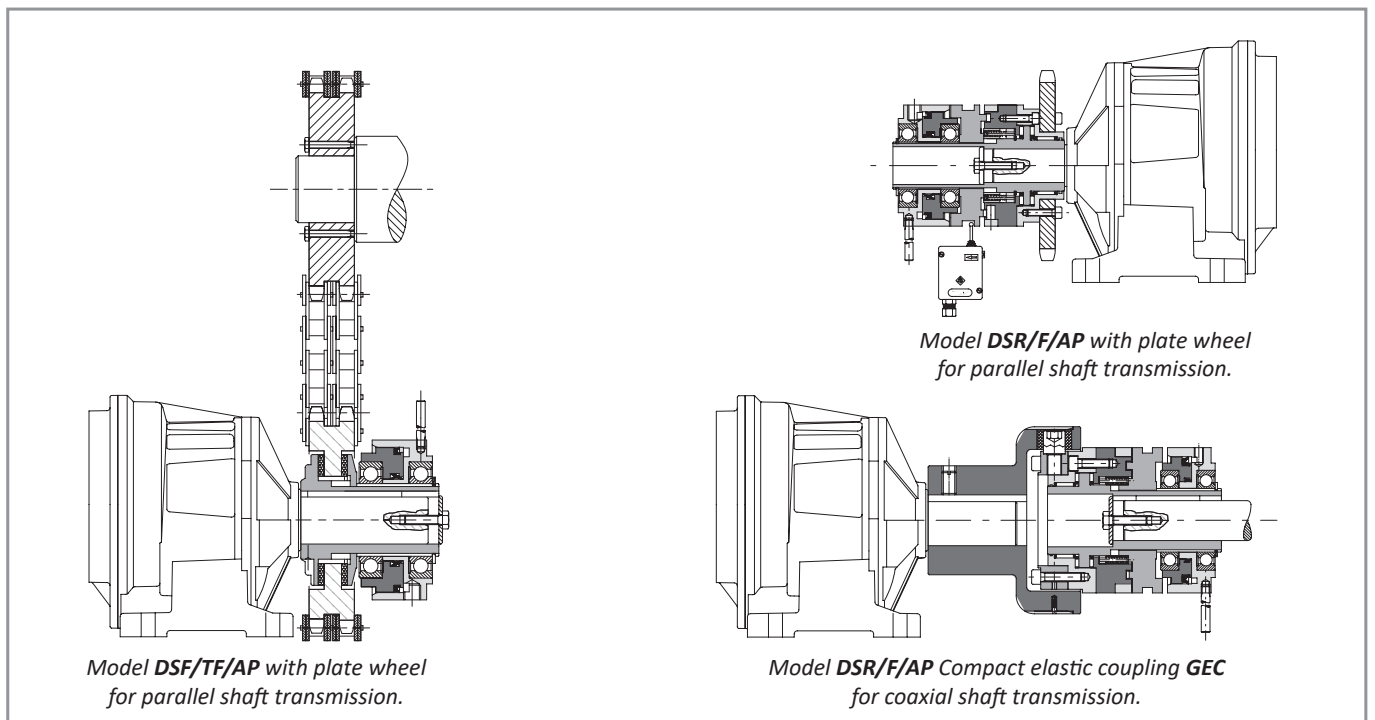

NOTES

- Avoid rigid locking of the anti-rotating pin of the cylinder as it can cause imbalances during rotation.
- The engagement of these devices must take place at low speed or with the machine stopped.

DSR/F/AP - roller phase pneumatic clutch: technical data

- Transmission through rollers with re-engagement in phase 360° (equidistant on request, 30°, 45°, ...).
- Free rotation for long periods after overload: ... / CS.
- Suitable for high rotation speeds.
- Maintenance free for high reliability.
- Arranged to add a microswitch / proximity to stop the motor drive.
- Torque range: 5 – 30 KNm; max. bore $\phi 120$ mm.

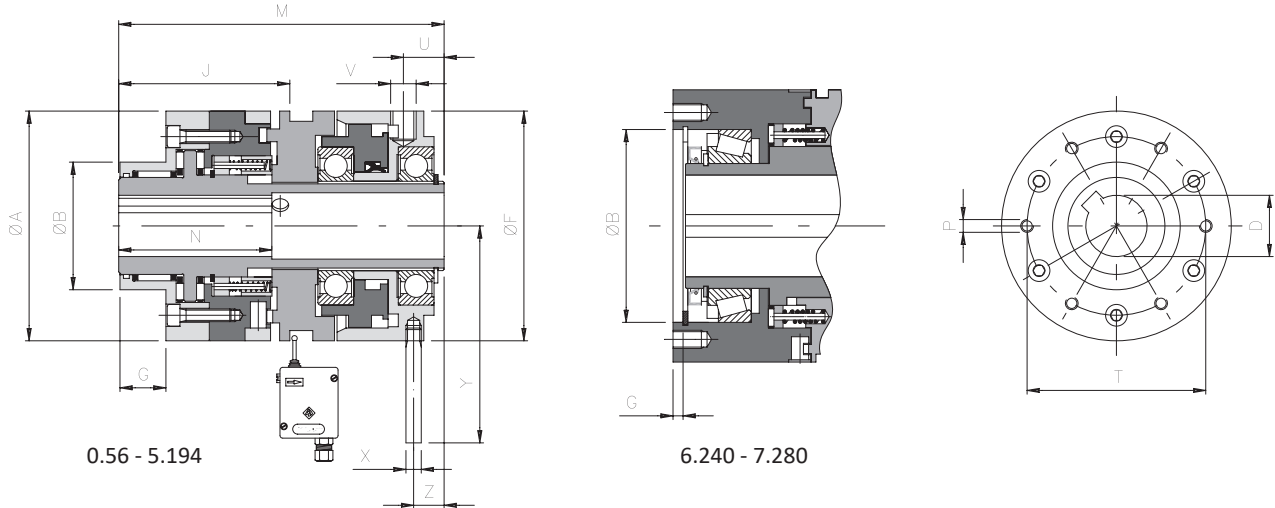

DIMENSIONS

Size	A	Standard flange				D H7		F	J	M	N	U	V	Z	X	Y	Inertia [kgm ²]		Max speed [Rpm]	Weight [kg]
		B h7	G	P	T	min	max										Flange side	Cylinder side		
0.56	56	38	10	M5	48	10	18*	56	56	97	45	11,5	1/8"	7,5	6	63	0,000152	0,000301	11000	1,5
1.90	90	50	18	M5	70	13	25	90	67,5	127,5	60	15	1/4"	11	6	80	0,001791	0,002622	7000	5
2.110	110	60	20	M6	89	18	38	110	85	147,5	70	17,5	1/4"	13,5	8	105	0,005122	0,006831	5000	9
3.130	130	80	19	M8	105	23	45	130	90,5	160	100	18,5	1/4"	14,5	8	115	0,010921	0,014132	4300	13,3
4.160	160	100	22	M10	125	31	55	160	109	191,5	115	25	1/4"	17	10	146	0,030883	0,030793	3600	19
5.194	194	120	26	M12	155	39	65	215	125	201,5	145	30	1/4"	22	12	184	0,059572	0,093061	3200	35,8
▲ 6.240 CB	240			M16	200	51	90	290		306,5										
▲ 6.240 CA	240			M16	200	51	90	290		356,5										
▲ 7.280 CB	280			M20	230	51	120	345		320										
▲ 7.280 CA	280			M20	230	51	120	345		375										

TECHNICAL DETAILS

Size	Torque [Nm]	Torque transmission [Nm] according to the pressure [bar]							
		1	2	3	4	5	6	10	15
0.56	7 - 70	7	11	16	20	24	29	45	70
1.90	15 - 280	15	35	55	75	95	115	185	280
2.110	20 - 480	20	50	85	125	160	195	330	480
3.130	25 - 780	25	80	135	195	250	310	520	780
4.160	55 - 1335	55	150	245	340	435	530	900	1335
5.194	330 - 3970	330	550	830	1085	1340	1600	2600	3970
▲ 6.240 CB	1100 - 5800	1100	2000	3000	3900	4800	5800	-	-
▲ 6.240 CA	3400 - 15000	3400	6200	9040	11760	15000	-	-	-
▲ 7.280 CB	1500 - 7500	1500	2500	3700	5000	6200	7500	-	-
▲ 7.280 CA	5000 - 30000	5000	10000	15000	20000	25000	30000	-	-

▲ On request

NOTES

- Weights are relevant only to the pilot bore (DSR/F/AP), inertias refer to the connection (DSR/F/AP) hole max.
- Microswitches EM1 or EM2 and inductive sensor PRX see page 73
- DH7*: finished bore max diameter with reduced keyway UNI7510.

... + GEC - model with compact elastic coupling: technical data

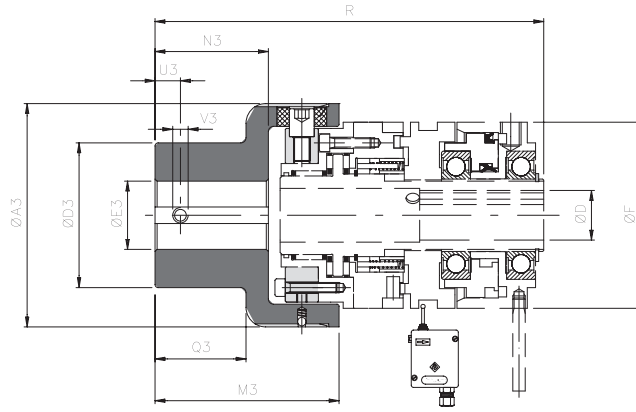

DIMENSIONS

Size		Torque [Nm]		A3	D3	E3 H7		M3	N3	U3	V3	Q3	D H7		F	R	U3	V3
DSR/F/AP	GEC	Nom	Max			pilot bore	max						min	max				
0.56	0	70	110	78	50	10	35	63,5	32	10	M5	28	10	18*	56	142	10	M5
1.90	1	280	420	108	70	12	48	89	49	12	M6	44	13	25	90	188	12	M6
2.110	2	570	860	130	80	15	55	111	65	15	M8	59	18	38	110	228	15	M8
3.130	3	980	1500	161	100	15	68	140	85	15	M8	77	23	45	130	268	15	M8
4.160	4	2340	3600	206	120	20	80	168	105	20	M10	97	31	55	160	323	20	M10
5.194	5	3880	5800	239	135	30	90	201	130	20	M10	120	39	65	215	360	20	M10
6.240 CB	6	15000	20000	315	215	40	150						51	90				
6.240 CA													51					
7.280 CB	7	30000	35000	364	240	40	180						51	120				
7.280 CA													51					

TECHNICAL DETAILS

Size		Misalignments						Max speed [Rpm]	Weight [Kg]
DSR/F/AP	GEC	Angular α [°]		Axial X [mm]		Radial K [mm]			
		continuous	intermittent	continuous	intermittent	continuous	intermittent		
0.56	0	1°	1° 30'	± 0,7	± 1,5	0,5	0,7	5500	1,1
1.90	1	0° 48'	1°	± 0,7	± 1,5	0,5	0,7	5000	3,3
2.110	2	0° 36'	0° 48'	± 0,7	± 1,5	0,6	0,7	4500	5,9
3.130	3	0° 30'	0° 42'	± 0,8	± 1,6	0,6	0,8	4000	10,9
4.160	4	0° 24'	0° 30'	± 0,8	± 1,6	0,6	0,8	3100	19,8
5.194	5	0° 24'	0° 30'	± 0,8	± 1,6	0,6	0,8	2800	30,5
6.240	6	0° 24'	0° 30'	± 0,8	± 1,6	0,6	0,8	-	-
7.280	7	0° 24'	0° 30'	± 0,8	± 1,6	0,6	0,8	-	-

OTHER COUPLING MODELS ON REQUEST

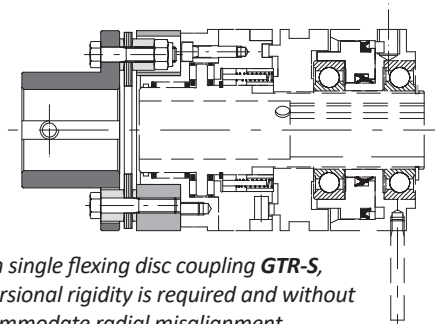

Model **DSR/F/AP** with single flexing disc coupling **GTR-S**, for applications where torsional rigidity is required and without the ability to accommodate radial misalignment.

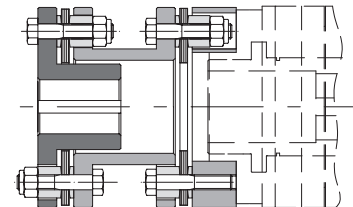

Model **DSR/F/AP** with double flexing torsionally rigid metal disc coupling **GTR-D**, when torsional rigidity is required and ability to accommodate radial misalignment.

NOTES

▲ On request

- These details refer only for the coupling (GEC). Weights are relevant only to the pilot bore (GEC). for clutch details see on page 67.
- **DH7***: finished bore max diameter with reduced keyway UNI7510.
- Microswitches EM1 or EM2 and inductive sensor PRX see page 73

DSF/TF/AP - friction pneumatic clutch: technical data

- ⊙ Friction torque transmission.
- ⊙ As tensioner, brake and torque limiter (safety coupling).
- ⊙ Constant adjustment of the calibration torque.
- ⊙ Available with special friction rings for specific requirements.
- ⊙ Available in version to stop the transmission after an overload: .../SI.
- ⊙ Torque range: 3 – 875 Nm; max. bore \varnothing 65 mm.

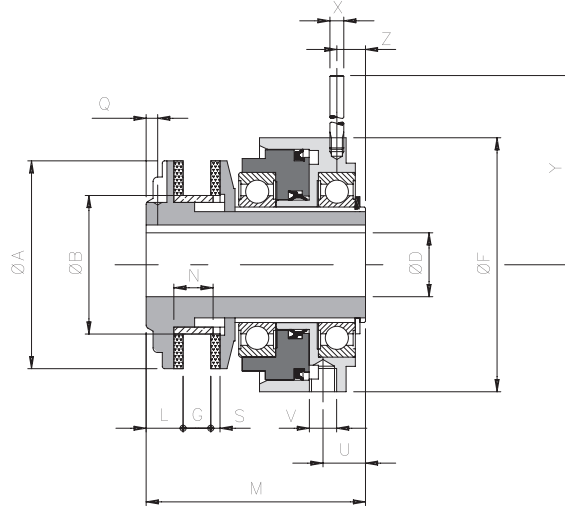

DIMENSIONS AND TECHNICAL DETAILS

Size	A	B h7	DH7		F	G		L	M	N	On request	S	U	V	Z	X	Y	Inertia [Kgm ²]	max speed [Rpm]	Weight [Kg]
			min	max		Q														
0.50	50	36	8	19*	56	3,5	6	11	62	10	3,5 - M4	3	11	1/8"	7	6	58	0,000065	7600	0,7
1.70	70	45	10	25*	90	5	10	15	85	15	4,5 - M4	4	14,5	1/4"	10,5	6	80	0,000332	5450	2,4
2.90	90	60	15	38	110	6,5	12	16	95	17	5 - M6	4	17,5	1/4"	13,5	8	105	0,001024	4250	4,3
3.115	115	72	19	45	130	9	16	18	113	21	5 - M6	4	18,5	1/4"	14,5	8	115	0,004192	3350	7,0
4.140	140	85	25	55	160	13	19	20	128	25	6 - M6	5	24,5	1/4"	17	10	146	0,008521	2750	11,9
5.170	170	98	29	65*	215	15	22	22,5	139,5	28	6,5 - M8	5	26,5	1/4"	18	12	184	0,019153	2250	19,8

TORQUE TRANSMISSION

Size	Torque [Nm]	Torque transmission [Nm] in according to pressure [bar]						
		1	2	3	4	5	6	10
0.50	3 - 20	3	5	7	9	11	13	20
1.70	6 - 70	6	10	19	28	36	43	70
2.90	15 - 135	15	27	42	57	73	88	135
3.115	25 - 220	25	52	79	105	130	153	220
4.140	70 - 330	70	115	145	175	205	230	330
5.170	170 - 875	170	280	390	500	600	700	875

▲ On request

NOTES

- **DH7***: finished bore max diameter with reduced keyway UNI7510.
- Weights are relevant only to the connection (DSF/TF/AP), inertias refer to the connection (DSF/TF/AP) hole max.

.../TAC - version with chain coupling: technical data

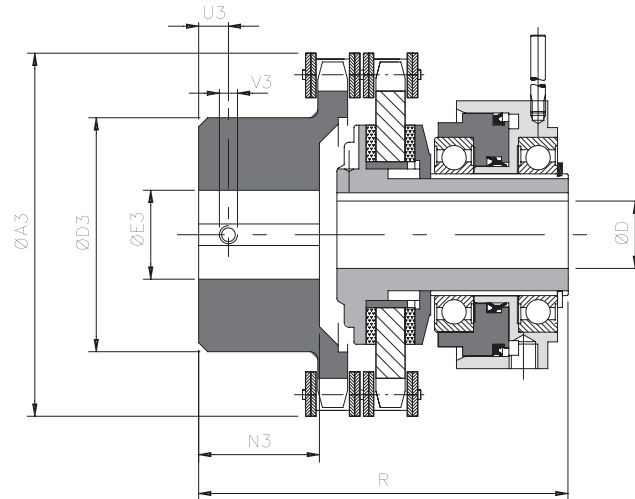

DIMENSIONS

Size	Torque [Nm]	A3	D3	E3 H7		N3	D H7		F	R	U3	V3	Max speed [Rpm]	Weight [Kg]
				pilot bore	max		min	max						
0.50	3 - 20	75	50	12	28	19	8	19*	56	84	8	M4	7600	0,6
1.70	6 - 70	101	70	16	38	29	10	25*	90	117	8	M6	5450	1,7
2.90	15 - 135	126	89	20	55	38	15	38	110	138	12	M6	4250	4,1
3.115	25 - 220	159	112	20	70	56,5	19	45	130	174	12	M6	3350	7,1
4.140	70 - 330	184	130	28	80	59	25	55	160	193,5	15	M8	2750	14,1
5.170	170 - 875	216	130	30	80	88	29	65*	215	233	15	M8	2250	19,2

▲ On request

OTHER COUPLING MODELS

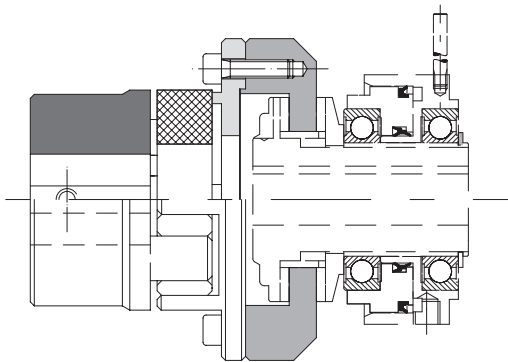

Model **DSF/TF/AP** with elastic jaw coupling **GAS** to accomodate high misalignments.

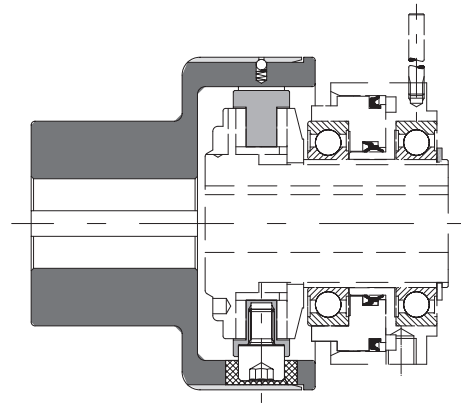

Model **DSF/TF/AP** with compact elastic coupling **GEC** for simple maintenance without removing the coupling.

NOTES

- Data is relevant to the whole assembly (DSF/TF/AP/TAC).
- Weights are relevant only to the pilot bore (DSF/TF/AP/TAC).
- **DH7***: finished bore max diameter with reduced keyway UNI7510.

AP - pneumatic clutch: versions on request

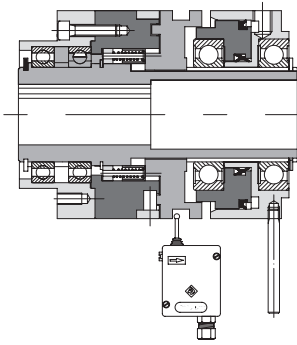

DSR/F/AP/CS

Version with ball bearings as an alternative to the rollers. Suitable for long rotation on disengagement.

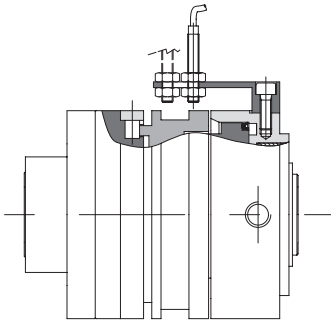

.../PRX

Version with proximity inductive sensor PRX M8x1, integrated into the DSR/F/AP. Compact and versatile solution, without adding equipment and/or external components.

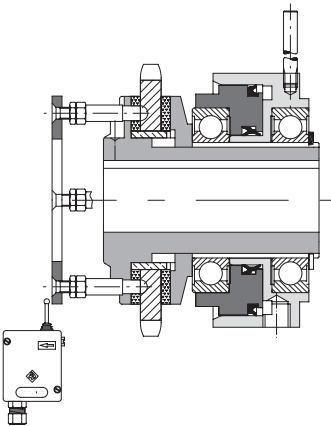

DSF/TF/AP/SI

Friction clutch with intervention signal and further automatic re-engagement. This characteristic requires particular machining on the drive element, which has to be supplied together with the torque limiter.

AP - pneumatic clutch: additional information

EXAMPLE CIRCUIT CONNECTION TYRE

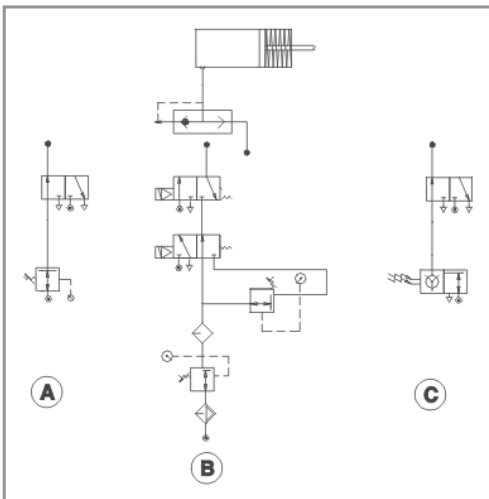

The pneumatic clutch are designed for the connection of pneumatic circuit with connection type "GAS".
Some examples for the control to the pressure are shown here:

- A) Adjustable pressure with pressure regulator.
- B) Control of two pressures using solenoid valves.
- C) Control of variable pressure by PLC.

AP - pneumatic clutch: additional information

ORDER EXAMPLE

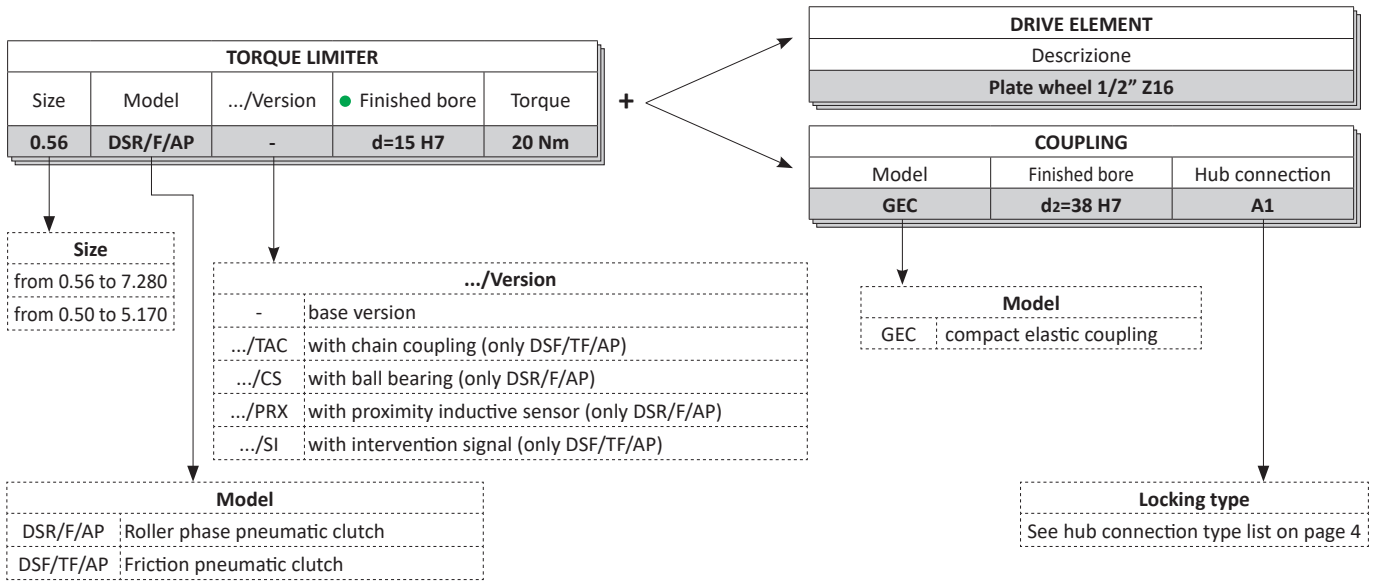

- Both models available only with finished bores.

FLOHR - PRODUCTS OVERVIEW

Gears

- Spiral toothed bevel gears
- Bevel gears
- Worm gears
- Spur gears
- Special gears



Gear Technology

- Bevel gearboxes
- Angle-planetary gearboxes
- Worm gearboxes
- Cam drives and indexing units
- Cam components
- Special gearboxes



Couplings

- Rigid and flexible couplings
- Frictional connections
- Drum-coupling
- Gear-couplings
- Safety couplings



Friction connections

- Shrink discs
- Shaft couplings
- Flange couplings
- Locking units



Clamping technology

- Manual and pneumatic clamping solutions
- Power clamps
- Pivot units
- End effector solutions
- Linear units
- Grippers



Belt drives

- V-belt and flat belt pulleys
- Flywheels
- Special pulleys
- Motor clamping systems
- Drive belts
- Customer designed castings
- Accessories



Sensor systems

- Incremental encoders
- Magnetic encoders
- Absolute encoders
- Electronic overspeed switches
- Electronic position switches
- Universal encoder systems
- Systems



Contract manufacturing

- Turning, milling, grinding
- Grooving and broaching
- Balancing
- Calculation and design
- Assembly
- Service and repair



FLOHR
INDUSTRIETECHNIK GMBH

FLOHR Germany

FLOHR INDUSTRIETECHNIK GmbH
Im Unteren Tal 1
D-79761 Waldshut-Tiengen
Phone: +49 (0) 77 51 / 87 31 0
info@flohr-industrietechnik.de
www.flohr-industrietechnik.de

FLOHR Switzerland

FLOHR INDUSTRIETECHNIK
Zilistude 164
CH-5465 Mellikon
Phone: +41 (0) 56 / 267 08 10
info@flohr.ch
www.flohr.ch

FLOHR Austria

FLOHR INDUSTRIETECHNIK
Bucherstraße 37b
A-6922 Wolfurt
Phone: +43 (0) 5572 / 372 158
info@flohr.at
www.flohr.at